

Intrinsically Safe Pressure Gauge Model PI

High Accuracy: 0.2% Full Scale

 Factory Mutual Approved

Ranges to 10,000 PSI - Gage, Absolute, Vacuum or Compound

- Stainless Steel Construction
- On/Off Switch
- CE Compliant
- 9 Volt Battery Power
- High/Low Capture & Store
- 4 1/2 Digit Display
- Additional Information at www.dctinstruments.com/pidata.htm

As an in-process gauge or portable calibrator, the hand-held Model PI delivers long-lasting, high accuracy performance. Accuracy of 0.2% coupled with an enhanced resolution, 4 1/2 digit display makes this unit an excellent transfer standard for calibrating pressure measuring equipment.

The PI is rugged and features High/Low pressure capture. These units are manufactured from stainless steel and use reliable sensor technology which has no moving parts, requires little recalibration and has excellent over- pressure tolerance. NEMA 4 construction provides EMI and RFI protection.

Units of measure are field-selectable and the unit is offered with gage, absolute, vacuum, or compound reference.



The DCT Series PI Digital Gauges have the following complete Factory Mutual Approved Classifications:

Class I: gases and vapor	Division 1: present or likely to be present in normal operation	Group A: Acetylene Group B: Hydrogen Group C: Acetaldehyde, Ethylene, Methyl Ether
Class II: combustible dust	Division 2: not present in normal operation	Group D: Acetone, Gasoline, Methanol, Propane
Class III: fibers		Group E: Metal Dust Group F: Carbon Dust Group G: Grain Dust

Intrinsically safe systems limit the thermal and electrical energy to the hazardous area to prevent ignition.

Distributed By:

DCT Instruments

DCT Instruments/Sensotec, Inc.
2080 Arlingate Lane
Columbus, Ohio 43228
www.dctinstruments.com

1-800-328-1028
Tel: 614-850-6020
Fax: 614-850-1111
E-mail: dct@sensotec.com

DIMENSIONS

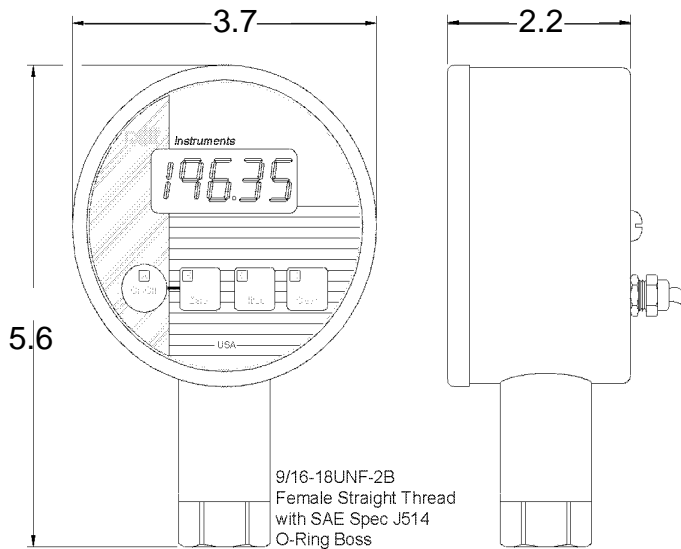

Request drawing before designing mountings or fixtures.
Specifications subject to change without notice.

ACCESSORIES

PRESSURE ADAPTER

- To 1/4 - 18 NPT Female
- To 1/4 - 18 NPT Male
- To 7/16 - 20 UNF - Male with 37 deg flare
(Call factory for other fittings)

CARRYING CASE

PANEL MOUNTING RING

NIST CERTIFICATION

(In addition to NIST STATEMENT)

ORDER CODE

Zinc Plated Stainless

Steel	Steel
AD6	SS6
AD7	SS7
AD9	SS9

CC2

MR2

NISTCERTS

SPECIFICATIONS

Accuracy:	0.2% of FS BFSL
Diameter:	3.7 inches
Rating:	NEMA 4(Also provides temperature range of 0-180°F)
Operating Temperature:	Standard: 30-160°F Optional: 0-180°F
Pressure Range 0 to:	15, 50, 100, 200, 500, 750, 1000, 1500, 2000, 5000, 7500, 10000 PSI
Display:	4 1/2 LCD Digits - 0.5 inches high
Pressure Port:	9/16-18 UNF - 2B - Female straight thread with SAE Spec J514 O-ring boss
Power: Model AIW:	One or two 9 volt alkaline batteries (included)
Model AIV:	11 to 32 VDC @ 100 mA (3 ft. cable included)
Wetted Parts:	Stainless steel
Case Material:	Stainless steel
Low Battery Indication:	Standard
High & Low Capture:	Standard
Update Speed:	3 per second
Face Membrane:	Tactile Feedback Raised Buttons
Calibration Data:	Stored on Memory Chip

ORDERING INFORMATION

ORDER CODE

PI W 200 G Z

* = Example

SERIES

PI

POWER

W = Battery Powered (9 volt alkaline)*

PRESSURE RANGE (PSI)

15 = 0-15	500 = 0-500	2K = 0-2000
50 = 0-50	750 = 0-750	5K = 0-5000
100 = 0-100	1K = 0-1000	7.5K = 0-7500
200 = 0-200*	1.5K = 0-1500	10K = 0-10000

REFERENCE

- G = Gage (std) reads zero at atmosphere *
- A = Absolute (opt) reads zero at vacuum (15 psi or higher)
- V = Vacuum (opt) scaled in In Hg (15 psi or lower)
- C = Compound (opt) reads both positive & negative (vacuum) pressure

ELECTRICAL CONNECTION

Z = No electrical connection (Model PIW - 9 volt battery)*

Call factory for availability of other electrical connections and cable lengths.

FIELD SELECTABLE STANDARD UNITS OF MEASURE

Each gauge has the following scaling built in for field selection:

Bar = Bar	Ft H2O = Feet of water
mBar = Millibar	In H2O = Inches of water
kPa = Kilopascals	In Hg = Inches of mercury
MPa = Megapascals	mmHg = Millimeters of mercury

Consult factory for other units of measure not listed

PRESSURE RANGE (PSI)	MAXIMUM SAFE OVER PRESSURE (PSI) See note (1) Below	INCREMENTAL DISPLAY STEPS
0 - 15 = 15	75	.01
0 - 50 = 50	250	.05
0 - 100 = 100	500	.1
0 - 200 = 200	1,000	.1
0 - 500 = 500	1,500	.5
0 - 750 = 750	1,500	.5
0 - 1,000 = 1K	2,000	1
0 - 1,500 = 1.5K	3,000	1
0 - 2,000 = 2K	4,000	1
0 - 5,000 = 5K	7,500	5
0 - 7,500 = 7.5K	12,000	5
0 - 10,000 = 10K	15,000	5

(1) Maximum Safe Overpressure is the pressure which the unit can experience occasionally without loss of accuracy or permanent damage.



DCT Instruments

A Product of Sensotec®

E-mail: dct@sensotec.com

www.dctinstruments.com

©Copyright 2001 DCT Instruments

PI01015.0