

TOP MOUNTING

Liquid Displacer Level Switches

DESCRIPTION

Magnetrol's displacement type level switches offer the industrial user a wide choice of alarm and control configurations. Each unit utilizes a simple buoyancy principle and is well suited for simple or complex applications, such as foaming or surging liquids or agitated fluids, and usually costs less than other types of level switches.

FEATURES

- Narrow or wide level ranges achieved through multiple switch mechanism capability.
- Displacers adjustable at any point along the suspension cable.
- Anti-surge design eliminates the possibility of switch shortcycling.
- Standard 3 m (10') of suspension cable, included for all models.
- Field adjustable set point and switch differential.
- Wide choice of displacer materials (other materials as listed at request)
- Wide choice of housings and switch mechanisms
- Standard anti corrosive protection.
- Optional:
 - NACE construction (MR-01-75)
 - Proof-er[®] ground check
 - Floating roof models
 - High pressure models
 - Models for interface.

APPLICATIONS

- Foaming or surging liquids
- Agitated fluids
- Sewage handling
- Dirty liquids
- Paints
- Varnishes
- Heavy oils
- Liquids with solids

Displacer level switches for single or multiple pump control/level alarm

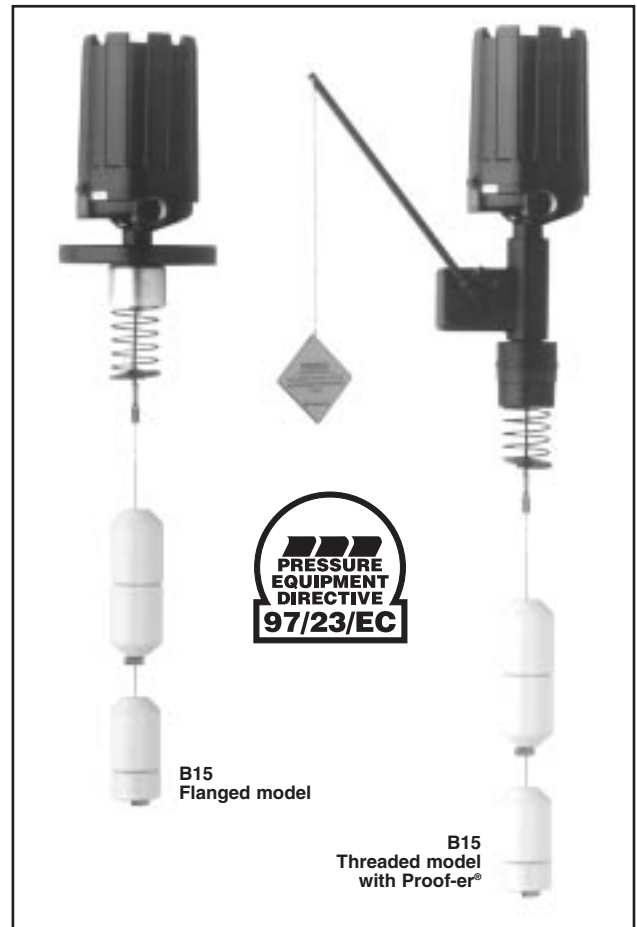

AGENCY APPROVALS

Agency	Approval
ATEX	II 2G EEx d II C T6, explosion proof II 1G EEx ia II C T6, intrinsically safe
CENELEC	EEx d II C T6, explosion proof
CCE ^①	R1 (1) 136/MI/433, explosion proof
FM	Class I, Div. 1, Groups C & D Class II, Div. 1, Groups E, F & G, Type NEMA 7/9
FM/CSA ^②	Non-Hazardous area Explosion proof area – Groups B, C, D, E, F & G Type NEMA 4X/7/9
SAA ^②	Explosion proof area
LRS	Lloyds Register of Shipment (marine applications)
GOST/ GOSGORTECHNADZOR ^②	Russian Authorisation Standards
Other approvals are available, consult factory for more details	

^① For CCE approved units, use the ATEX explosion proof model numbers.

^② Consult factory for proper model numbers.

PRINCIPLE OF OPERATION

Standard controls

Operation is based upon simple buoyancy, whereby a spring is loaded with weighted displacers which are heavier than the liquid. Immersion of the displacers in the liquid results in buoyancy force change, which moves the spring upward. Since the spring moves only when the level moves on a displacer, spring movement (A) is always a small fraction of the level travel between displacers (B).

A magnetic sleeve (C) is connected to the spring and operates within a non-magnetic barrier tube (D). Spring movement causes the magnetic sleeve to attract a pivoted magnet (E), actuating a switch mechanism (F) located outside the barrier tube. Built-in limit stops, prevent over stroking of the spring under level surge conditions.

Proof-er® controls

The purpose of the Proof-er® is to check the operation of a displacer control without having to raise the level in the tank. This is accomplished by pulling downward on the Proof-er® cable. This causes the spring loaded lever arm to lift the switch actuator, simulating a high or high high level condition. When the cable is released, the Proof-er® returns the actuator to its previous position to resume normal operation.

Floating roof controls

The floating roof control is designed for installation on 'barrier' (floating roof) tanks. The control may be furnished with a lead displacer to prevent sparking. A stainless steel displacer is optionally available.

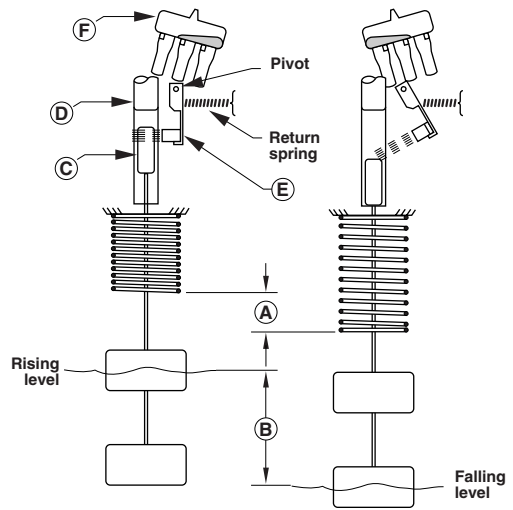

MOUNTING

Standard models

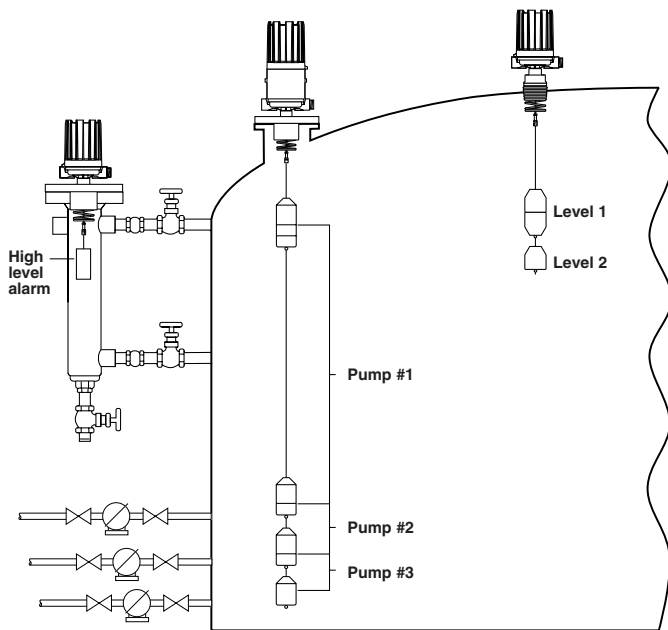

Floating roof models (with Proof-er® as shown below)

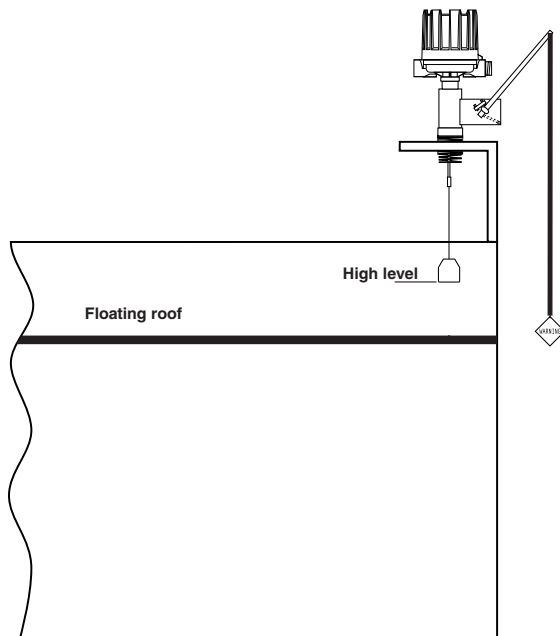

AVAILABLE SWITCH MECHANISMS

Type of switch module ^①	Max. Process Temp. ^②	Switch ratings – A res. ^③			Code
		24 V DC	240 V AC	120 V AC	
Micro switch	max 120 °C (250 °F)	6	15	15	B / Q ^⑤
Micro switch	max 230 °C (450 °F)	10	15	15	C / O ^⑤
Micro switch - DC current	max 120 °C (250 °F)	10	–	10	D
Micro switch with gold alloy contacts	max 120 °C (250 °F)	1	–	1	U
Hermetically sealed micro switch	max 260 °C (500 °F)	5	5	5	HS ^④
Hermetically sealed micro switch with silver plated contacts	max 230 °C (450 °F)	3	1	1	W
Hermetically sealed micro switch with gold plated contacts	max 230 °C (450 °F)	0,5	0,5	0,5	X
Proximity switch - type SJ 3.5 SN	max 100 °C (210 °F)	NA	NA	NA	V
Mercury switch	max 260 °C (500 °F)	10	6,5	13	A / N ^⑤
Pneumatic bleed type (open air)	max 200 °C (400 °F)	NA	NA	NA	J
Pneumatic non bleed type (closed circuit)	max 200 °C (400 °F)	NA	NA	NA	K

^① For applications with heavy vibration, consult factory for suited switch modules.

^② Max process temperature is specified at 40 °C (100 °F) ambient temperature and for non condensing applications.

^③ For more details - see bulletin BE 42-120.

^④ For condensing applications, max process temperature is down-rated to 200 °C (400 °F) @ 40 °C (100 °F) ambient.

^⑤ N, Q and O are the equivalent switch modules for models C10/C15.

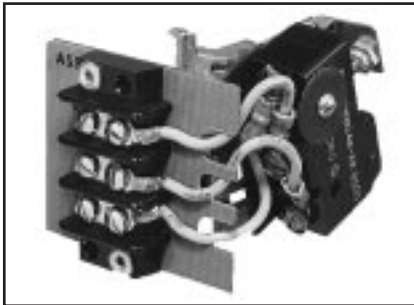

Type B, C, D, O, Q & U



Type HS

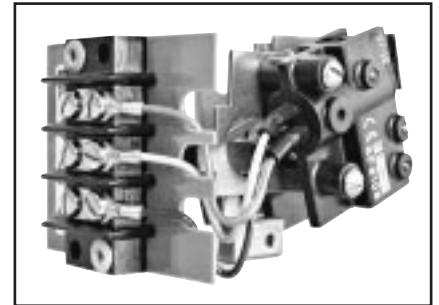

Type W & X

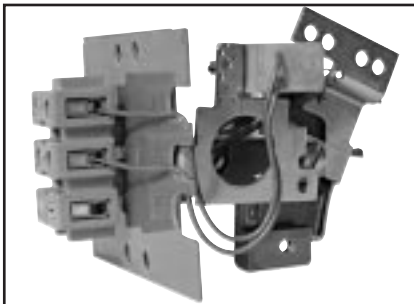

Type V



Type A & N



Type J & K

AVAILABLE HOUSINGS



- For Non Ex use
- IP 66
- Die cast Aluminium
- 2 Entries (one plugged)
- Standard blue anti corrosive coating
- Housing heater/drain available, consult factory



- For Exd/Exi use
- IP 66
- Die cast Aluminium
- 2 Entries (one plugged)
- Standard blue anti corrosive coating
- ATEX II 2G EEx d II C T6
- ATEX II 1G EEx ia II C T6



- For Exd use
- IP 66
- Cast Iron
- One entry (2 entries at request)
- Standard blue anti corrosive coating
- CENELEC EEx d II C T6



- For pneumatic switches
- IP 53 (NEMA 3R)
- IP 55 optional at request
- Alu base / cold rolled steel cover
- Standard blue anti corrosive coating



- For Exd use
- IP 66 (NEMA 7/9)
- Die cast Aluminium
- 2 Entries (one plugged)
- Standard blue anti corrosive coating
- FM, Class I, Div. 1, Groups C & D
- FM, Class II, Div. 1, Groups E, F & G

SINGLE SWITCH MODELS

Models A15 – Level alarm applications Narrow differential type

These instruments are factory calibrated to operate over a narrow level differential band and are ideally suited for liquid level alarm applications, on either high or low level.

The operating level is fully adjustable by simply repositioning the displacer along its suspension cable.

The differential band is ± 51 mm (2") in water and varies with liquid specific gravity.



Models A10 – Pump or valve control Wide differential type

These wide differential units are factory calibrated to actuate as a liquid level reaches a given displacer and to remain actuated until the level reaches a second displacer.

The minimum differential band is approximately 152 mm (6") in water and varies with liquid specific gravity.

The maximum differential is determined by the length of the displacer suspension cable.



DUAL SWITCH MODELS

Models B15 Narrow differential type

These instruments utilize two switches, each actuated at a different level and each calibrated with a narrow differential band.



Models B10 Wide differential type

These wide differential tandem units are factory calibrated with a choice of several operating sequences.



OPERATING SEQUENCES

Model B10 units are available factory calibrated with a choice of switch operating sequence. Five of the most popular sequences are described below.

When ordering B10 units, an operating sequence and specific gravity MUST be provided.

PUMP CONTROL PLUS ALARM

Arrangement N° 1 — fill with high level alarm

At the lowest level the pump starts. When the level rises to the middle displacer, the pump stops. If the level continues to rise, the upper displacer actuates the alarm switch which remains actuated until the level drops to the middle displacer.

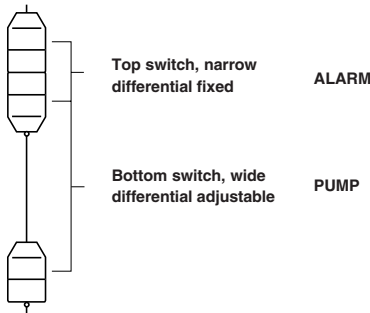

CONTROL OF 2 PUMPS

Arrangement N° 4

In this sequence N° 1 pump starts as the level rises to the middle displacer. Should the level continue to rise to the upper displacer, N° 2 pump is actuated. Both pumps operate until the level is dropped to the lower displacer.

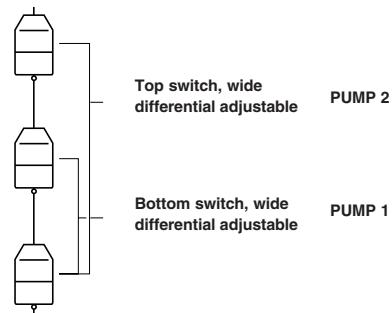

Arrangement N° 2 — drain with low level alarm

The sequence of arrangement N° 1 can be reversed to provide pump start at high level and pump stop at low level followed by low level alarm operation.

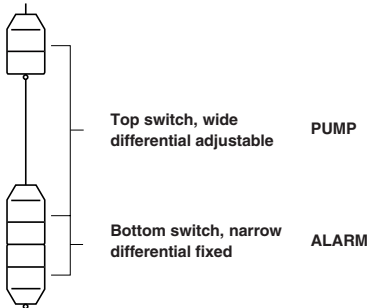

Arrangement N° 5

The pumping sequence of Arrangement N° 4 can be reversed for a pump "fill" application.

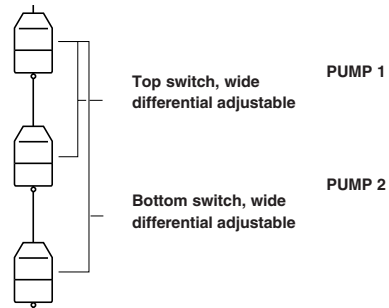

CONTROL OF 2 PUMPS OF DIFFERENT CAPACITY

Arrangement N° 3 — fill or drain

Two pumps are used to keep a tank filled. When the level falls to the middle displacer, a small N° 1 pump starts. A second larger pump is started should the level continue to fall to the bottom displacer.

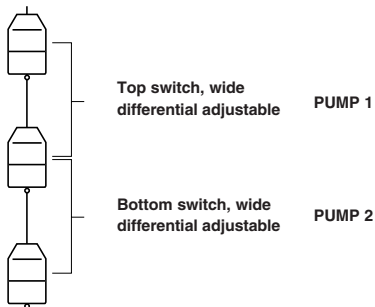

TRIPLE SWITCH MODELS



Models C10 Wide differential type

These wide differential type switches are designed to provide three electrically separate control signals in sequence as liquid level varies.

These units are factory calibrated with a choice of several sequences.



Models C15 Narrow differential type

These instruments are factory calibrated to operate over a narrow level band while providing three electrically separate control signals in sequence as liquid level varies.

OPERATING SEQUENCES

Model C10 units are available factory calibrated with a choice of switch operating sequence. Seven of the most popular sequences are described below.

When ordering C10 units, an operating sequence and specific gravity MUST be provided.

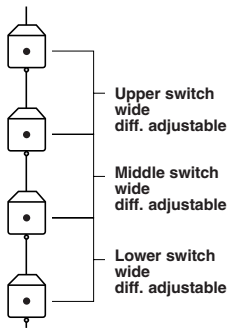

Arrangement A

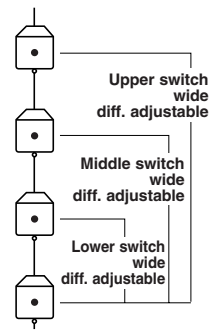

Arrangement B

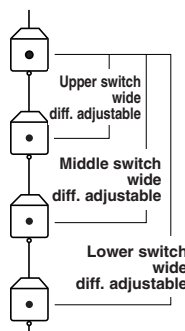

Arrangement C

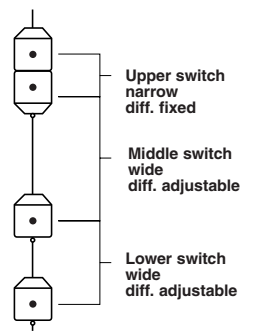

Arrangement D

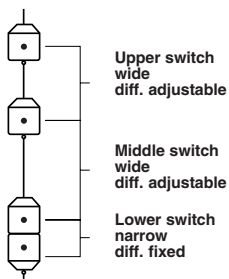

Arrangement E

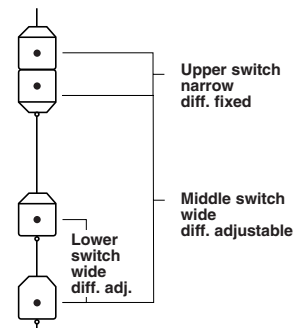

Arrangement F

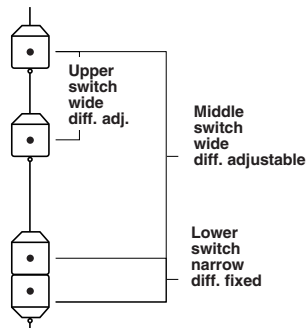

Arrangement G

When ordering C15 units, a specific gravity MUST be provided.

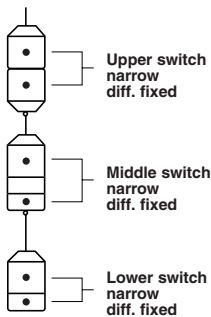

SELECTION DATA

Narrow Differential: for actuation of an alarm or system shutdown - up to 3 setpoints.

Wide Differential: switch differential for valve or pump control - up to 3 pump control functions.

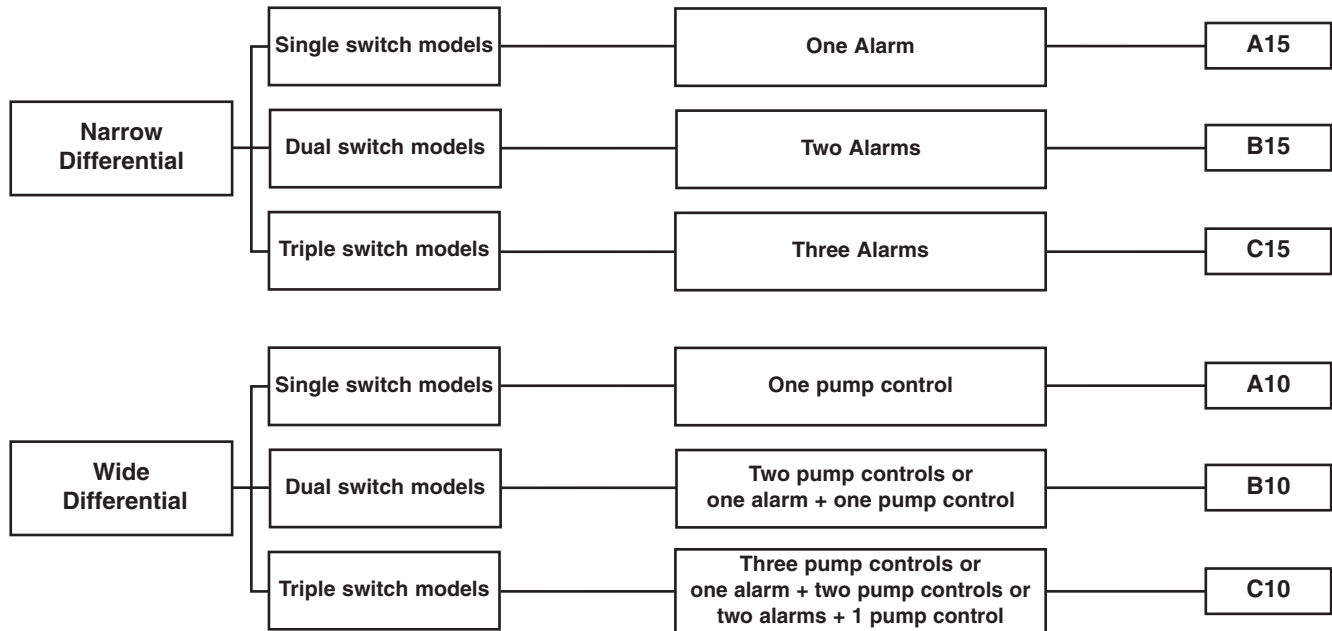

Specific gravity limits – not for floating roof models.

P.N. code	Liquid temp.		Specific gravity - ranges	
	°C	°F	Porcelain	SST
A10	40	100	0.60 to 1.20	0.60 to 1.20
	90	200	0.70 to 1.20	0.70 to 1.20
	150	300	0.80 to 1.20	0.80 to 1.20
	200	400	1.00 to 1.20	0.90 to 1.20
	260	500	1.10 to 1.20	1.00 to 1.20
A15	40	100	0.60 to 2.40	0.40 to 1.65
	90	200	0.62 to 2.40	0.40 to 1.65
	150	300	0.65 to 2.40	0.50 to 1.65
	200	400	0.70 to 2.40	0.55 to 1.65
	260	500	0.75 to 2.40	0.60 to 1.65

Specific gravity limits – not for floating roof models.

P.N. code	Liquid temp.		Specific gravity - ranges	
	°C	°F	Porcelain	SST
B10	40	100	0.60 to 1.50	0.50 to 1.00
	90	200	0.64 to 1.50	0.50 to 1.00
	150	300	0.80 to 1.50	0.60 to 1.00
	200	400	1.00 to 1.50	0.72 to 1.00
	260	500	1.10 to 1.50	0.84 to 1.00
B15	40	100	0.95 to 1.20	0.70 to 1.20
	90	200	1.10 to 1.20	0.80 to 1.20
	150	300	–	0.90 to 1.20
	200	400	–	1.00 to 1.20
	260	500	–	1.04 to 1.20

Specific gravity limits – not for floating roof models.

P.N. code	Liquid temp.		Specific gravity - ranges	
	°C	°F	Porcelain	SST
C10	55	130	0.65 to 1.25	0.58 to 1.25
	90	200	0.95 to 1.10	0.76 to 1.00
	150	300	–	0.82 to 1.00
C15 ^①	55	130	0.80 to 1.25	0.65 to 1.00

^① Consult factory for high temperatures

EXPEDITE SHIP PLAN (ESP)

Several mechanical switches are available for quick shipment, within max. 3 weeks after factory receipt of purchase order, through the Expedite Ship Plan (ESP).

Models covered by ESP service are conveniently grey coded in the selection data charts.

To take advantage of ESP, simply match the grey coded model number codes (standard dimensions apply).

ESP service may not apply to orders of ten units or more. Contact your local representative for lead times on larger volume orders, as well as other products and options.

SELECTION DATA

A complete measuring system consists of:

- Order code for **standard** models (each unit is factory calibrated to operate on a given specific gravity within the min and the max values listed per model) or
- Order code for **floating roof** models or
- Order code for **modified** models or adders: put an "X" in front of the closest matching order code and specify the modifications/adders separately
eg. XA15-AE2A-BAQ X = with material certification EN 10204 / DIN 50049-3.1.B

- Order code for **standard** displacer switches

BASIC MODEL NUMBER

– units for ALARM use ONLY

A 1 5	One adjustable narrow differential
B 1 5	Two adjustable narrow differentials
C 1 5	Three adjustable narrow differentials, specify specific gravity of medium separately

– units for ALARM/PUMP control use

A 1 0	One adjustable wide differential
B 1 0	Two adjustable wide differentials, specify operating sequence and specific gravity separately (see p. 5 & 8)
C 1 0	Three adjustable wide differentials, specify operating sequence and specific gravity separately (see p. 7 & 8)

MATERIALS OF CONSTRUCTION (3 m (10') of suspension cable is standard supplied)

Code	Spring	Trim	Process Connection	Displacer-clamps/ cable	Magnetic sleeve	Construction
A	Inconel	316 SST	Carbon steel	316 SST (1.4401)	400 series SST	Standard
B		(1.4401)			316 SST (1.4401)	
D		316 SST (1.4401)				
E		316 SST	Carbon steel	Monel (2.4360)	400 series SST	
F		(1.4401)				
K		316 SST (1.4401)		316 SST (1.4401)		
L	316 SST (1.4401)	Carbon steel	316 SST (1.4401)	400 series SST		

PROCESS CONNECTION

– threaded

E 2	2 1/2" NPT
-----	------------

– ANSI flanges

G 3	3" 150 lbs ANSI RF
G 4	3" 300 lbs ANSI RF
H 3	4" 150 lbs ANSI RF
H 4	4" 300 lbs ANSI RF
K 3	6" 150 lbs ANSI RF
K 4	6" 300 lbs ANSI RF

– DIN flanges

8 A	DN 80, PN 16 DIN 2527 form C
8 B	DN 80, PN 25/40 DIN 2527 form C
1 A	DN 100, PN 16 DIN 2527 form C
1 B	DN 100, PN 25/40 DIN 2527 form C

DISPLACER MATERIAL AND PROOF-ER® OPTION

(for pressure ratings, refer to physical specifications table)

– without Proof-er®

can be used for NACE models

A	Porcelain
B	316 SST (1.4401)

– with low pressure Proof-er®

not for NACE & not for C10-C15 models

D	Porcelain
E	316 SST (1.4401)

– with medium pressure Proof-er®

not for NACE & not for B10-B15, C10-C15 models

G	Porcelain
H	316 SST (1.4401)

SWITCH MECHANISM & ENCLOSURE

Refer to table selections per displacer type A10-A15 (p. 10-11), B10-B15 (p. 11) & C10-C15 (p. 11).

1							
---	--	--	--	--	--	--	--

complete order code for standard models

2. Order code for **floating roof** models (not for NACE constructions)

BASIC MODEL NUMBER – units for ALARM use ONLY

A	1	5	One adjustable narrow differential
B	1	5	Two adjustable narrow differentials

MATERIAL OF CONSTRUCTION (3 m (10') of suspension cable is standard supplied)

Code	Spring	Trim	Process Connections	Displacer clamps and cable	Magnetic sleeve	Construction
A	Inconel	316 SST (1.4401)	Carbon steel	316 SST (1.4401)	400 series SST	Standard

PROCESS CONNECTION – size rating (consult factory for DIN flanges)

– threaded

E	2	2 1/2" NPT
---	---	------------

– ANSI flanges

G	3	3" 150 lbs ANSI RF
G	4	3" 300 lbs ANSI RF
H	3	4" 150 lbs ANSI RF
H	4	4" 300 lbs ANSI RF
K	3	6" 150 lbs ANSI RF
K	4	6" 300 lbs ANSI RF

DISPLACER MATERIAL AND PROOF-ER® OPTION (for pressure ratings, refer to physical specifications table)

– without Proof-er®

K	Lead
M	Stainless steel

– with low pressure Proof-er®

L	Lead
N	Stainless steel

SWITCH MECHANISM & ENCLOSURE

Refer to table selections per displacer type A10-A15 (below) & B10-B15 (p. 11)

1	5						
---	---	--	--	--	--	--	--

complete order code for **floating roof** models

Select electric switch mechanism & enclosure: **A10 — A15 type displacer switches** (see page 3 for switch ratings)

Switch Type	Switch and Housing codes for A10										Switch and Housing codes for A15												
	Weather proof (IP 66)		ATEX (IP 66)				CENELEC (IP 66)		FM (IP 66)		Weather proof (IP 66)		ATEX (IP 66)				CENELEC (IP 66)		FM (IP 66)				
			II 2G EEx d II C T6		II 1G EEx ia II C T6		EEx d II C T6		NEMA 7/9				II 2G EEx d II C T6		II 1G EEx ia II C T6		EEx d II C T6		NEMA 7/9				
	cast Aluminium		cast Aluminium		cast Aluminium		cast Iron		cast Alu.		cast Aluminium		cast Aluminium		cast Aluminium		cast Iron		cast Alu.				
M20 x 1,5		1" NPT		M20 x 1,5		1" NPT		M20 x 1,5		3/4" NPT		1" NPT		M20 x 1,5		1" NPT		M20 x 1,5		3/4" NPT		1" NPT	
A	SPDT	A2B	AAB	AK9	AC9	–	–	AK5	AU5	AKB	A2Q	AAQ	AH9	AA9	–	–	AK5	AU5	AKQ				
	DPDT	A8B	ADB	AN9	AF9	–	–	AD5	AW5	ANB	A8Q	ADQ	AJ9	AB9	–	–	AD5	AW5	ANQ				
B	SPDT	B2B	BAB	BK9	BC9	–	–	BK5	BU5	BKB	B2Q	BAQ	BH9	BA9	–	–	BK5	BU5	BKQ				
	DPDT	B8B	BDB	BN9	BF9	–	–	BD5	BW5	BNB	B8Q	BDQ	BJ9	BB9	–	–	BD5	BW5	BNQ				
C	SPDT	C2B	CAB	CK9	CC9	C2T	CAT	CK5	CU5	CKB	C2Q	CAQ	CH9	CA9	C2S	CAS	CK5	CU5	CKQ				
	DPDT	C8B	CDB	CN9	CF9	C8T	CDT	CD5	CW5	CNB	C8Q	CDQ	CJ9	CB9	C8S	CDS	CD5	CW5	CNQ				
D	SPDT	D2B	DAB	DK9	DC9	–	–	DK5	DU5	DKB	D2Q	DAQ	DH9	DA9	–	–	DK5	DU5	DKQ				
	DPDT	D8B	DBB	DN9	DF9	–	–	DD5	DW5	DNB	D8Q	DDQ	DJ9	DB9	–	–	DD5	DW5	DNQ				
HS	SPDT	H7A	HM2	HFC	HA9	–	–	HB3	HB4	HM3	H7A	HM2	HFC	HA9	–	–	HB3	HB4	HM3				
	DPDT	H7C	HM6	HGC	HB9	–	–	HB7	HB8	HM7	H7C	HM6	HGC	HB9	–	–	HB7	HB8	HM7				
U	SPDT	U2B	UAB	UK9	UC9	U2T	UAT	UK5	UU5	UKB	U2Q	UAQ	UH9	UA9	U2S	UAS	UK5	UU5	UKQ				
	DPDT	U8B	UDB	UN9	UF9	U8T	UDT	UD5	UW5	UNB	U8Q	UDQ	UJ9	UB9	U8S	UDS	UD5	UW5	UNQ				
V	–	–	–	–	VCS	VES	–	–	–	–	–	–	–	V5S	VBS	–	–	–					
W	SPDT	W2B	WAB	WK9	WC9	W2T	WAT	WK5	WU5	WKB	W2Q	WAQ	WH9	WA9	W2S	WAS	WK5	WU5	WKQ				
	DPDT	W8B	WDB	WN9	WF9	W8T	WDT	WD5	WW5	WNB	W8Q	WDQ	WJ9	WB9	W8S	WDS	WD5	WW5	WNQ				
X	SPDT	X2B	XAB	XK9	XC9	X2T	XAT	XK5	XU5	XKB	X2Q	XAQ	XH9	XA9	X2S	XAS	XK5	XU5	XKQ				
	DPDT	X8B	XDB	XN9	XF9	X8T	XDT	XD5	XW5	XNB	X8Q	XDQ	XJ9	XB9	X8S	XDS	XD5	XW5	XNQ				

Select pneumatic switch mechanism & enclosure: **A10 — A15 type displacer switches**

Pneumatic switch type	Max supply pressure bar (psi)	Max process temperature °C (°F)	Bleed orifice ø mm (inches)	A10 codes	A15 codes
				NEMA 3R (IP 53)	NEMA 3R (IP 53)
Series J (open air)	6,9 (100)	200 (400)	1,60 (0.063)	JGF	JDE
	4,1 (60)	200 (400)	2,39 (0.094)	JHF	JEE
Series K (closed circuit)	6,9 (100)	200 (400)	–	KOF	KOE

Select electric switch mechanism & enclosure: **B10 — B15 type displacer switches** (see page 3 for switch ratings)
(no pneumatic switch mechanisms available.)

Switch ^① Type		Switch and Housing codes for B10/B15								
		Weather proof (IP 66)		ATEX (IP 66)				CENELEC (IP 66)		FM (IP 66)
				II 2G EEx d II C T6		II 1G EEx ia II C T6		EEx d II C T6		NEMA 7/9
		cast Aluminium		cast Aluminium		cast Aluminium		cast Iron		cast Alu.
		M20 x 1,5	1" NPT	M20 x 1,5	1" NPT	M20 x 1,5	1" NPT	M20 x 1,5	3/4" NPT	1" NPT
A	SPDT	A4B	ABB	AL9	AD9	–	–	AL5	AV5	ALB
	DPDT	A1B	AEB	AP9	AG9	–	–	AO5	AY5	AOB
B	SPDT	B4B	BBB	BL9	BD9	–	–	BL5	BV5	BLB
	DPDT	B1B	BEB	BP9	BG9	–	–	BO5	BY5	BOB
C	SPDT	C4B	CBB	CL9	CD9	C4T	CBT	CL5	CV5	CLB
	DPDT	C1B	CEB	CP9	CG9	C1T	CET	CO5	CY5	COB
D	SPDT	D4B	DBB	DL9	DD9	–	–	DL5	DV5	DLB
	DPDT	D1B	DEB	DP9	DG9	–	–	DO5	DY5	DOB
U	SPDT	U4B	UBB	UL9	UD9	U4T	UBT	UL5	UV5	ULB
	DPDT	U1B	UEB	UP9	UG9	U1T	UET	UO5	UY5	UOB
W	SPDT	W4B	WBB	WL9	WD9	W4T	WBT	WL5	WV5	WLB
	DPDT	W1B	WEB	WP9	WG9	W1T	WET	WO5	WY5	WOB
X	SPDT	X4B	XBB	XL9	XD9	X4T	XBT	XL5	XV5	XLB
	DPDT	X1B	XEB	XP9	XG9	X1T	XET	XO5	XY5	XOB

^① Proximity switches (switch type V) are available, consult factory for proper ordering information.

Select electric switch mechanism & enclosure: **C10 — C15 type displacer switches** (see page 3 for switch ratings)
(no pneumatic switch mechanisms available.)

Switch Type		Switch and Housing codes for C10/C15	
		Weather proof (IP 66)	
		cast Aluminium	
		M20 x 1,5	1" NPT
N	SPDT	N6B	NCB
	DPDT	N1B	NEB
O	SPDT	O6B	OCB
	DPDT	O1B	OEB
Q	SPDT	Q6B	QCB
	DPDT	Q1B	QEB

PHYSICAL SPECIFICATIONS

Description		Specification
Measured variable		Liquid level
Physical range		Standard 3 m cable (field adjustable)
Process temperature Process pressure (for higher ratings consult factory)	Threaded models Flanged models	Porcelain displacers: ^① 55,1 bar @ 40 °C (800 psi @ 100 °F) 260 °C @ 17,2 bar (500 °F @ 250 psi) Stainless steel displacers: 49,6 bar @ 40 °C (720 psi @ 100 °F) 260 °C @ 34,5 bar (500 °F @ 500 psi) Flanged models are downrated to the design pressure of the selected flange
	Medium pressure Proof-er [®] models	8,6 bar @ 150 °C (125 psi @ 300 °F) ^①
	Low pressure Proof-er [®] models	1,7 bar @ 90 °C (25 psi @ 200 °F) ^①
Wetted materials	Spring	Inconel
	Displacer(s)	Porcelain ^① or 316 SST (1.4401)
	Cable and clamps	316 SST (1.4401), Monel (2.4360) or Hastelloy C (2.4819)
Process connection material		Carbon steel or stainless steel

^① Do not use porcelain displacers on non-vented boiler water condensate systems over 90°C (200°F).

ELECTRICAL SPECIFICATIONS

Description	Specification
Switch ratings	Up to 15 A @ 240 V AC (depending on switch mechanism) Up to 10 A @ 120 V DC (depending on switch mechanism)
Signal output	Single, dual or triple SPDT or DPDT contacts or single pneumatic
Switch types (see table on page 3)	Dry contact with standard or gold alloy contacts, Mercury, Hermetically sealed, Hermetically sealed with gold or silver plated contacts, Proximity switch, or single pneumatic bleed and non bleed
Approvals (see table on page 1)	ATEX II 2G EEx d II C T6, explosion proof ATEX II 1G EEx ia II C T6, intrinsically safe CENELEC EEx d II C T6, explosion proof FM/CSA/SAA, explosion proof LRS, Lloyds Register of Shipment (marine applications) GOST/GOSGORTECHNADZOR, Russian Authorisation standards Other approvals are available, consult factory.
Cable entries	M20 x 1,5 ISO, 1" NPT and 3/4" NPT (or others at request)

ELECTRICAL CONNECTION

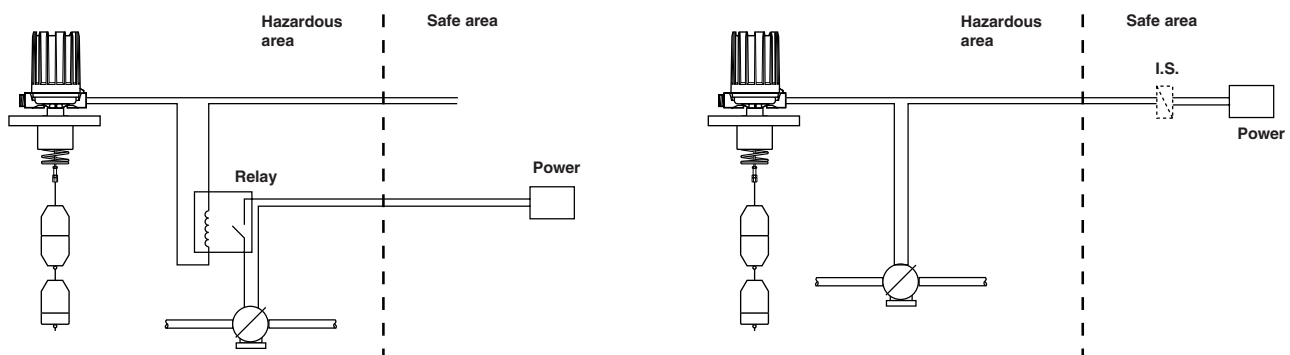

DIMENSIONS IN mm (inches) – housings

Models A10/A15/B10/B15
Threaded mounting

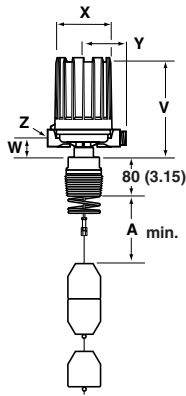

Models A10/A15/B10/B15
Flanged mounting

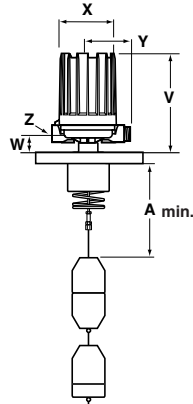

Models C10/C15
Threaded mounting

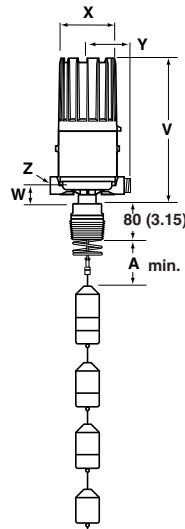

Models C10/C15
Flanged mounting

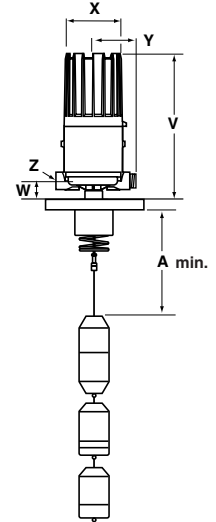

Housing type	Models	V		W		ø X		Y		Z	
		mm	inches	mm	inches	mm	inches	mm	inches		
Weatherproof - FM (NEMA 7/9) - ATEX (Cast Alu)	A10	257	10.12	42	1.66	151	5.93	109	4.29	M20 x 1,5 (*) or 1" NPT (2 entries - 1 plugged) (*) not for FM (NEMA 7/9)	
	A15 with HS-switch										
	B10										
	B15										
	A15 excl. HS-switch	202	7.94								
Weatherproof	C10 / C15	376	14.81								
CENELEC (Cast Iron)	A10 / A15 / B10 / B15	249	9.80	45	1.77	143	5.63	110	4.33		M20 x 1,5 or 3/4" NPT (single entry - 2 entries at request)
Pneumatics Switch Module J	A10	216	8.50	39	1.54	118	4.65	110	4.33		1/4" NPT
	A15	165	6.50								
Pneumatics Switch Module K	A10	216	8.50					130	5.12		
	A15	165	6.50								

Allow 200 mm (7.87") overhead clearance / All housings are 360 ° rotatable

Min. distance between mounting connection and top of displacer		A			
		Threaded		Flanged	
Models	Displacer Type	mm	inches	mm	inches
A10	Porcelain	127	5.00	178	7.00
	Stainless steel	121	4.75	171	6.75
A15	Porcelain	143	5.62	194	7.62
	Stainless steel	143	5.62	194	7.62
B10	Porcelain	124	4.88	175	6.88
	Stainless steel	121	4.75	171	6.75
B15	Porcelain	140	5.50	191	7.50
	Stainless steel	149	5.88	200	7.88
C10	Porcelain	162	6.38	213	8.38
	Stainless steel	146	5.75	197	7.75
C15	Porcelain	197	7.75	248	9.75
	Stainless steel	184	7.25	235	9.25

DIMENSIONS IN mm (inches) – displacers

Models A10/A15/B10/B15 - Standard models

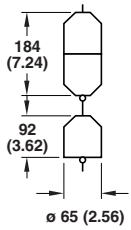
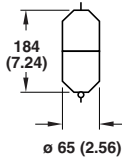
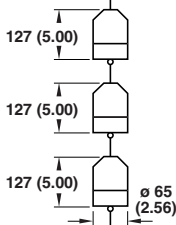
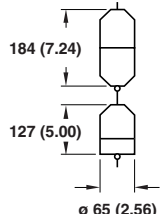
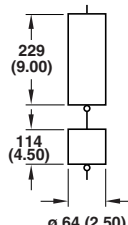
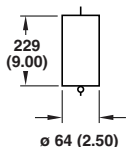
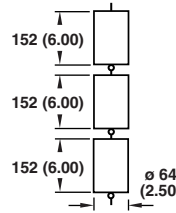
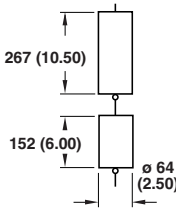
	A10	A15	B10	B15
Porcelain				
Stainless steel				

Models C10 & C15 - Standard models

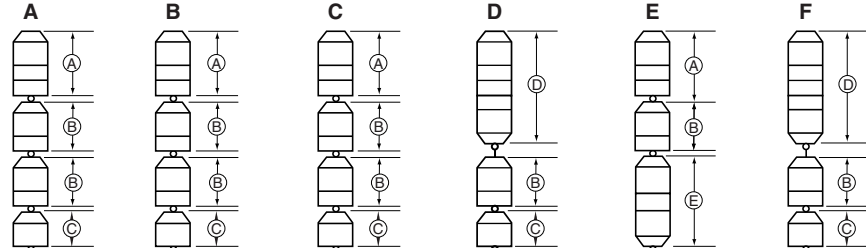
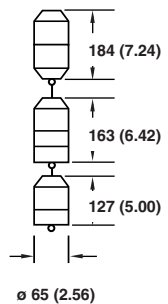
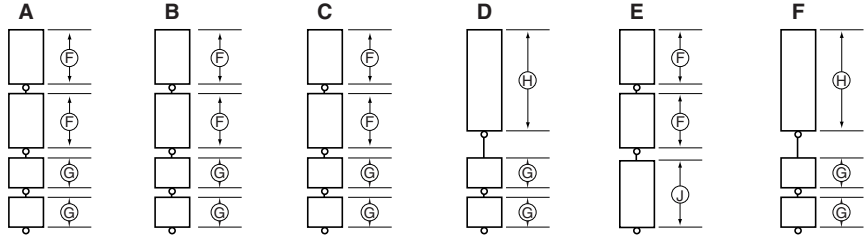
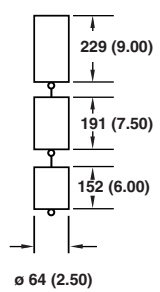
	C10 operating sequence	C15 operating sequence
Porcelain	<p>Arrangements (see page 7)</p>  <p>(A) 163 (6.42) (B) 127 (5.00) (C) 92 (3.62) (D) 291 (11.44) (E) 219 (8.64)</p> <p>Note: All displacers \varnothing 65 (2.56).</p>	
Stainless steel	<p>Arrangements (see page 7)</p>  <p>(F) 152 (6.00) (G) 114 (4.50) (H) 305 (12.00) (J) 229 (9.00)</p> <p>Note: All displacers \varnothing 64 (2.50).</p>	

DIMENSIONS IN mm (inches) – displacers

Models A10/A15/B10/B15 - Standard models

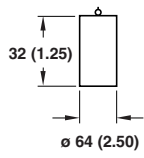
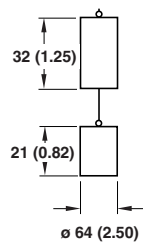
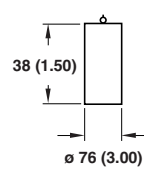
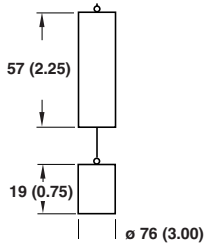
	A15	B15
Lead	 <p>32 (1.25) ø 64 (2.50)</p>	 <p>32 (1.25) 21 (0.82) ø 64 (2.50)</p>
Stainless steel	 <p>38 (1.50) ø 76 (3.00)</p>	 <p>57 (2.25) 19 (0.75) ø 76 (3.00)</p>

DIMENSIONS IN mm (inches) – Proof-er®

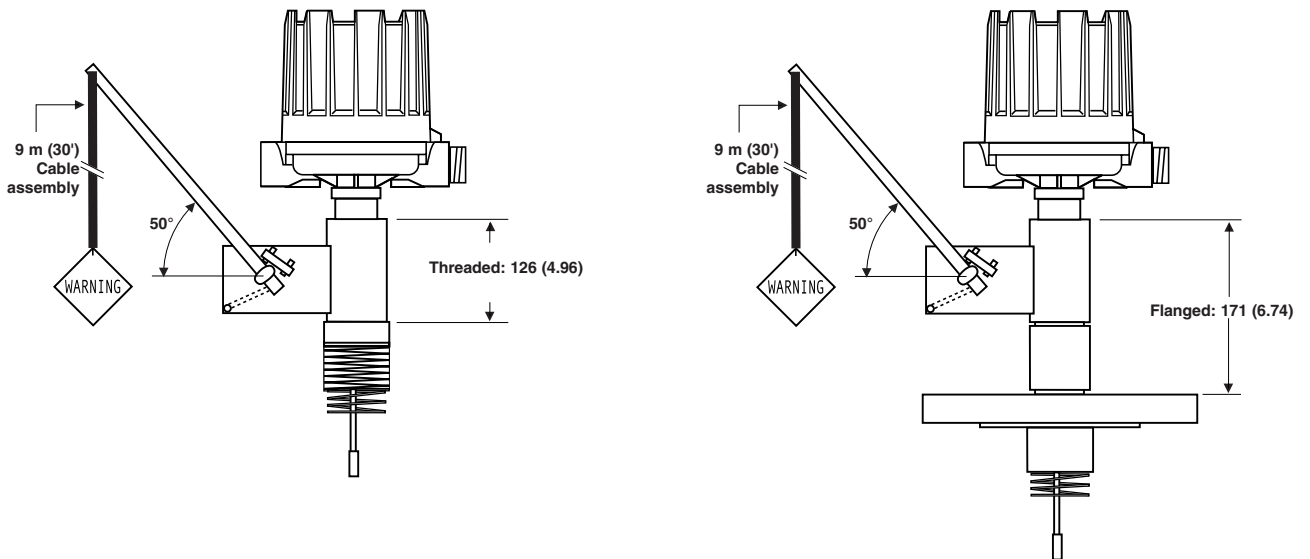



QUALITY ASSURANCE - ISO 9001

THE QUALITY ASSURANCE SYSTEM IN PLACE AT MAGNETROL GUARANTEES THE HIGHEST LEVEL OF QUALITY DURING THE DESIGN, THE CONSTRUCTION AND THE SERVICE OF CONTROLS. OUR QUALITY ASSURANCE SYSTEM IS APPROVED AND CERTIFIED TO **ISO 9001** AND OUR TOTAL COMPANY IS COMMITTED TO PROVIDING FULL CUSTOMER SATISFACTION BOTH IN QUALITY PRODUCTS AND QUALITY SERVICE.

PRODUCT WARRANTY

ALL MAGNETROL MECHANICAL LEVEL CONTROLS ARE WARRANTED FREE OF DEFECTS IN MATERIALS AND WORKMANSHIP FOR FIVE FULL YEARS FROM THE DATE OF ORIGINAL FACTORY SHIPMENT.

IF RETURNED WITHIN THE WARRANTY PERIOD; AND, UPON FACTORY INSPECTION OF THE CONTROL, THE CAUSE OF THE CLAIM IS DETERMINED TO BE COVERED UNDER THE WARRANTY; THEN, MAGNETROL INTERNATIONAL WILL REPAIR OR REPLACE THE CONTROL AT NO COST TO THE PURCHASER (OR OWNER) OTHER THAN TRANSPORTATION.

MAGNETROL SHALL NOT BE LIABLE FOR MISAPPLICATION, LABOR CLAIMS, DIRECT OR CONSEQUENTIAL DAMAGE OR EXPENSE ARISING FROM THE INSTALLATION OR USE OF THE EQUIPMENT. THERE ARE NO OTHER WARRANTIES EXPRESSED OR IMPLIED, EXCEPT, SPECIAL WRITTEN WARRANTIES COVERING SOME MAGNETROL PRODUCTS.



BULLETIN N°: BE 45-115.8
EFFECTIVE: MARCH 2002
SUPERSEDES: January 1999

UNDER RESERVE OF MODIFICATIONS

BENELUX	Heikensstraat 6, 9240 Zele, België Tel. +32 (0)52.45.11.11 • Fax. +32 (0)52.45.09.93 • E-Mail: info@magnetrol.be
DEUTSCHLAND	Schloßstraße 76, D-51429 Bergisch Gladbach-Bensberg Tel. 02204 / 9536-0 • Fax. 02204 / 9536-53 • E-Mail: vertrieb@magnetrol.de
FRANCE	Le Vinci 6 - Parc d'activités de Mitry Compans, 1, rue Becquerel, 77290 Mitry Mory Tél. 01.60.93.99.50 • Fax. 01.60.93.99.51 • E-Mail: magnetrolfrance@magnetrol.fr
ITALIA	Via Arese 12, I-20159 Milano Tel. (02) 607.22.98 (R.A.) • Fax. (02) 668.66.52 • E-Mail: mit.gen@magnetrol.it
UNITED KINGDOM	Unit 1 Regent Business Centre, Jubilee Road Burgess Hill West Sussex RH 15 9TL Tel. (01444) 871313 • Fax (01444) 871317 • E-Mail: sales@magnetrol.co.uk
INDIA	B4/115 Safdurjung Enclave, New Delhi 110 029 Tel. 91 (11) 6186211 • Fax 91 (11) 6186418 • E-Mail: magnetrolindia@vsnl.com

www.magnetrol.com

OUR NEAREST REPRESENTATIVE