



ECLIPSE® AURORA™

Guided Wave Radar Level Transmitter and Magnetic Level Indicator

DESCRIPTION

Aurora combines the operation of a conventional float operated Magnetic level indicator with the leading edge technology of Guided Wave Radar. The result is a true level measurement redundancy in a single 3" or 4" chamber design. The Eclipse Guided Wave Radar is a 2-wire loop powered 24 V DC liquid level transmitter utilizing Time Domain Reflectometry technology (TDR) to perform level measurement independent from media characteristics and process conditions. The Aurora™ is a completely self-contained unit for side mounting to a tank or vessel with threaded or flanged pipe connections.

FEATURES

- Complete redundant system whereby the measuring results of the Eclipse can be continuously checked against the level indication of the Magnetic Level Indicator.
- Pro-active maintenance can be planned ahead of time based upon the comparison of the measuring results of the two systems.
- No calibration required on either measuring system.
- 2-wire, intrinsically safe loop powered level transmitter.
- HART®, AMS®, Foundation Fieldbus and PACT^{ware} communication protocol.
- Up to 5,7 m (224") measuring range.
- Up to 103 bar (1500 psi) – optional up to 310 bar (4500 psi).
- Up to +400 °C (+750 °F) process temperature - non condensing applications.
- Up to 155 bar @ +345 °C (2250 psi @ +650 °F) for saturated steam applications.
- Suited for SIL 1 and SIL 2 loops (full FMEDA report available for Eclipse transmitter) – optional SIL 2/3.



APPLICATIONS

MEDIA: Clean liquids; hydrocarbons to water-based media (dielectric 1.4-100).

INTERFACE: Consult factory.

VESSELS: Most process or storage vessels up to rated probe temperature and pressure.

CONDITIONS: All level measurement and control applications including process conditions exhibiting visible vapors, foam, surface agitation, bubbling or boiling, high fill/empty rates, low level and varying dielectric media.

FULL REDUNDANCY

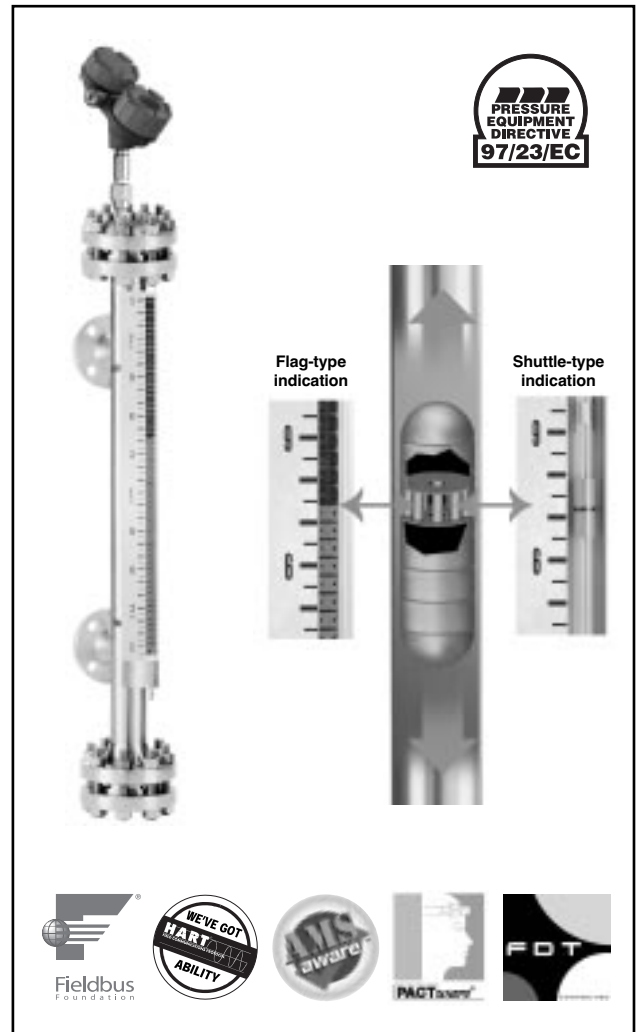

AGENCY APPROVALS

Agency	Approvals
ATEX	ATEX II 3 G EEx nA II T6, non sparking ATEX II 1 G EEx ia IIC T4, intrinsically safe ^① ATEX II 1/2 G D EEx d[ia] IIC T6, explosion proof
Stoomwezen	Secondary level safety device for steamdrums
TÜV	WHG § 19, overfill prevention
AIB	VLAREM II – 5.17.7
FM/CSA [®]	Non Incendive / Intrinsically safe / Explosion proof
LRS	Lloyds Register of Shipping (marine applications)
GOST/ GOSGORTECHNADZOR [®]	Russian Authorisation Standards

^① Fisco ATEX, intrinsically safe for units with Fieldbus Foundation

^② Consult factory for proper partnumbers

PRINCIPLE OF OPERATION

The coaxial GWR probe is separated from the float by means of a baffle plate. The baffle plate assures the free travel of the float by rising and falling level. The propagation and reflection of high frequency pulses to determine liquid level happens within the coaxial probe and is not impeded by the magnetic field of the magnets mounted inside the float of the indicator. These float magnets couple with the individual flags as level moves up and down within the pipe column.

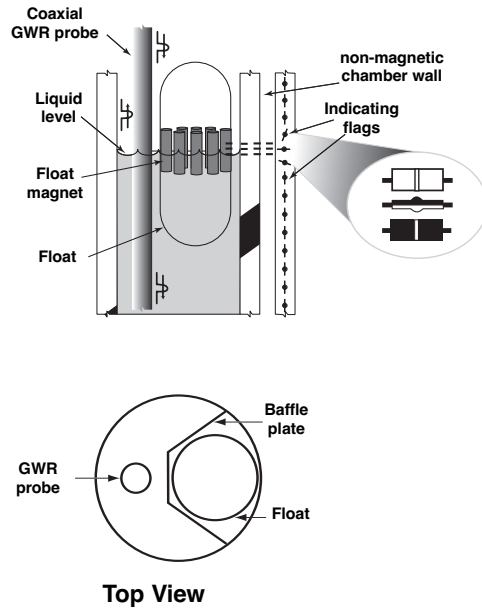

ELECTRICAL WIRING

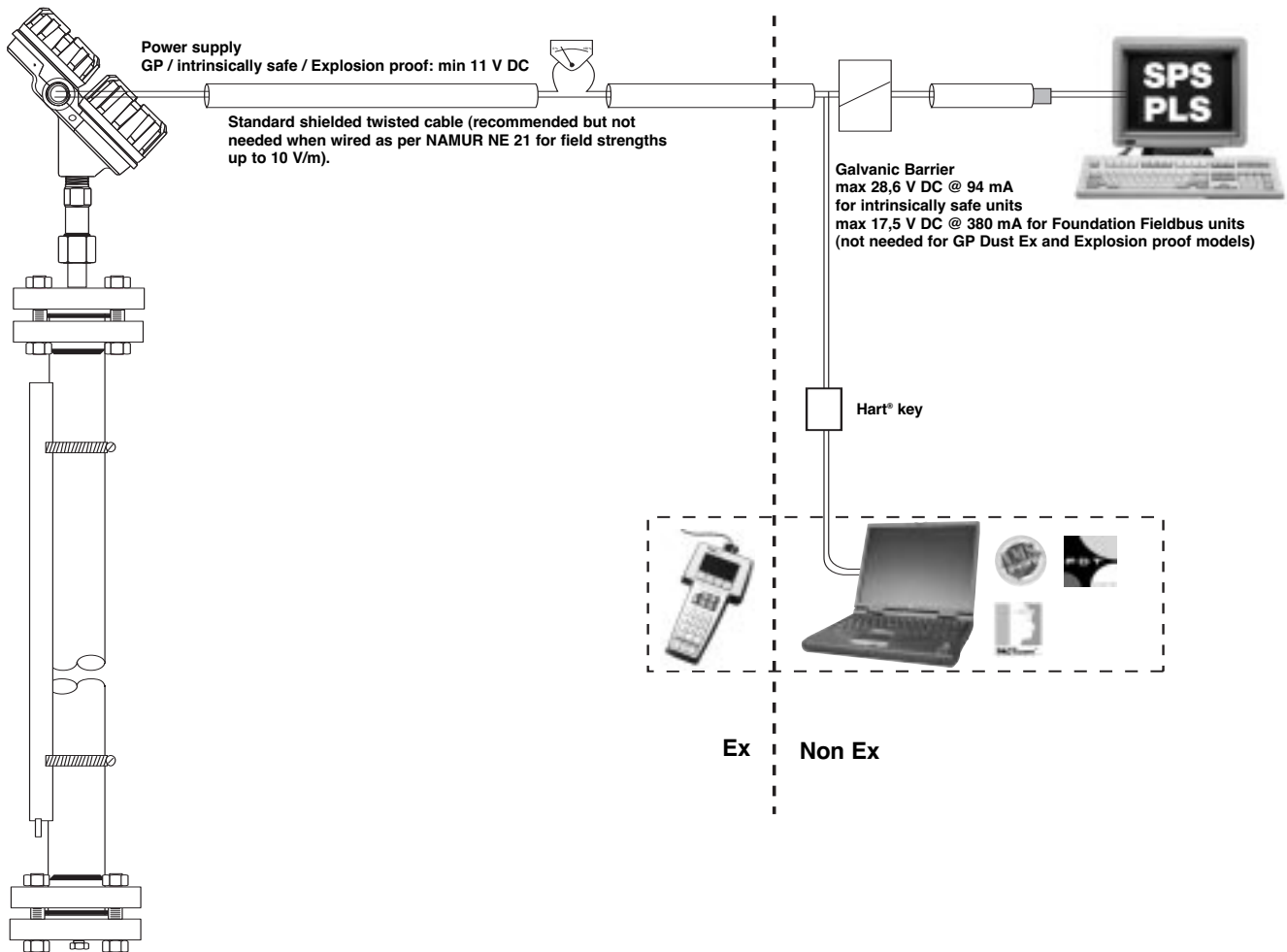

OPTIONS



Hot

Magnetic level indicators can be ordered with several different tracing options to heat the external chamber. Tracing systems require that a special blanket (custom designed to meet the customers specifications) cover the entire chamber and tracing equipment.

Cold

To facilitate operation where the product is kept cold via chillers, refrigerants and condensers, a frost extension option and low temperature insulation are offered. The frost extension is constructed of durable acrylic plastic and suitable for contact with media as cold as $-200\text{ }^{\circ}\text{C}$ ($-320\text{ }^{\circ}\text{F}$) such as liquid nitrogen.



Consult factory for ordering information.

SELECTION DATA

A complete measuring system consists of:

1. Order code for the Aurora - Magnetic Level Indicator
2. Order code for the Aurora - Guided Wave Radar Transmitter
3. Specify separately
 - operating and min S.G. of the media
 - max operating pressure and process temperature.

1. Order code for the Aurora - Magnetic Level Indicator

BASIC MODEL NUMBER

Code	Min. S.G.	Pressure rating in bar (psi)				float mat.	cage size
		40 °C (100 °F)	200 °C (400 °F)	315 °C (600 °F)	400 °C (750 °F)		
B G A	0,75	27,6 (400)	26,6 (386)	23,4 (340)	22,2 (322)	316 SST	3"
B G B	0,65	41,3 (600)	24,3 (352)	18,1 (262)	4,1 (60)	Titanium	3"
B G C	0,50	55,2 (800)	32,3 (469)	24,1 (349)	5,5 (80)	Titanium	4"
B G D	0,76	41,3 (600)	39,9 (579)	35,2 (510)	33,3 (483)	316 SST	3"
B G E	0,76	51,7 (750)	49,9 (723)	43,9 (637)	41,6 (603)	316 SST(*)	3"
B G F	0,65	75,8 (1100)	44,5 (645)	33,1 (480)	7,6 (110)	Titanium	3"
B G G	0,50	75,8 (1100)	44,5 (645)	33,1 (480)	7,6 (110)	Titanium	4"
B G H	0,75	62,0 (900)	59,9 (868)	52,8 (765)	49,9 (724)	316 SST(*)	4"
B G J	0,65	103 (1500)	60,7 (880)	45,2 (655)	10,3 (150)	Titanium(*)	4"
B G K	0,50	103 (1500)	60,7 (880)	45,2 (655)	10,3 (150)	Titanium(*)	4"

(*) pressurised float

MATERIALS OF CONSTRUCTION

Code flags only	Code with scale in cm	Code with scale in % of span	Flanges	Cage	Indication rail
A	B	C	Carbon steel	316/316L SST (1.4401/1.4404)	Aluminium
D	E	F	316/316L SST (1.4401/1.4404)		316 SST (1.4401)
G	H	J	Carbon steel		
K	L	M	316/316L SST (1.4401/1.4404)		

CAGE AND FLANGE RATING

A	150 lbs
B	300 lbs
C	600 lbs
D	900 lbs
E	1500 lbs
F	2500 lbs (max 345 bar (5000 psi))

1	PN 16	EN 1092-1 Type B1
2	PN 25/40	EN 1092-1 Type B1
3	PN 63	EN 1092-1 Type B2
4	PN 100	EN 1092-1 Type B2
5	PN 160	DIN 2638 Form E
6	PN 250	DIN 2628 Form E
7	PN 320	DIN 2629 Form E

PROCESS CONNECTION – SIZE

2	1"
3	1 1/2"
4	2"

B	DN 25
C	DN 40
D	DN 50

DIN sizes only in combination with flanged process conn.

PROCESS CONNECTION - TYPE

A	Threaded NPT-F
B	Socket weld
D	ANSI RF Slip on flanges up to 600 lbs rating
F	ANSI RJ Weld Neck flanges for 600 lbs up to 2500 lbs rating
1	EN/DIN Weld Neck flanges

MEASURING RANGE (center-to-center)

English ranges (dimensions as per specified inch dimension)

0 0 A	14" / 356 mm
0 0 B	32" / 813 mm
0 0 C	48" / 1219 mm
0 0 D	60" / 1524 mm
0 0 E	72" / 1829 mm

0 0 F	84" / 2134 mm
0 0 G	96" / 2438 mm
0 0 H	108" / 2743 mm
0 0 I	120" / 3048 mm

Metric ranges (specify per cm increments)

0 3 0	minimum 30 cm (11.81")
4 1 0	maximum 410 cm (161") - for 7MS
5 7 0	maximum 570 cm (224") - for 7MD/7MR

B	G								
---	---	--	--	--	--	--	--	--	--

complete order code for the Aurora - Magnetic Level Indicator

Dimensions in mm (inches)

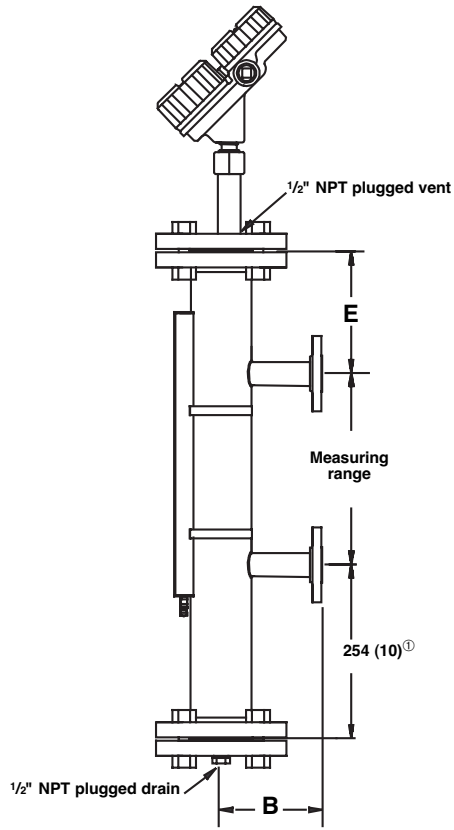

Flanged

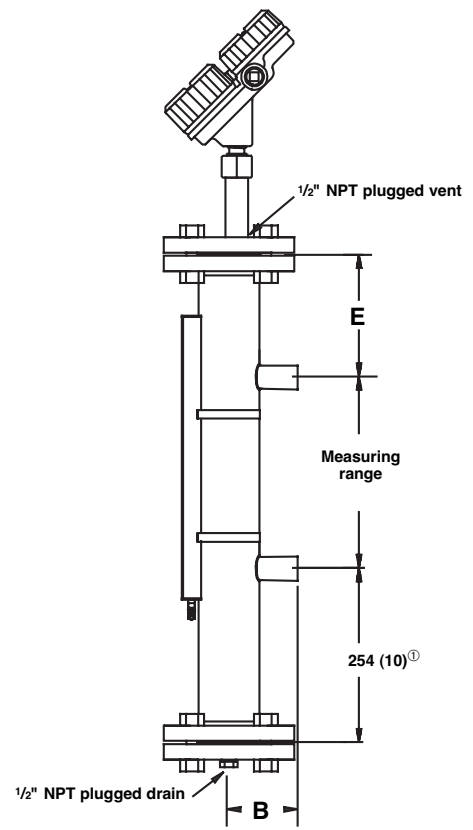

Threaded/Welded

① For S.G. < 0.8 and/or flange rating > 1500 lbs / PN 250, dimension will increase

Flanged 3" cages

Size	Connection	B	E
1"	NPT/SW - 150/300 lbs	69 (2.72)	178 (7.00)
1" 1/2"	NPT/SW - 150/300 lbs	81 (3.19)	178 (7.00)
2"	NPT/SW - 150/300 lbs	84 (3.31)	178 (7.00)
1"	RF Slip on flange - 150/300 lbs	170 (6.69)	178 (7.00)
1" 1/2"	RF Slip on flange - 150/300 lbs	180 (7.09)	178 (7.00)
2"	RF Slip on flange - 150/300 lbs	185 (7.28)	178 (7.00)
DN 25	PN 16/25/40 flange EN 1092-1 Type B1	170 (6.69)	178 (7.00)
DN 40	PN 16/25/40 flange EN 1092-1 Type B1	180 (7.09)	178 (7.00)
DN 50	PN 16 flange EN 1092-1 Type B1	185 (7.28)	178 (7.00)
DN 50	PN 25/40 flange EN 1092-1 Type B1	188 (7.40)	178 (7.00)

Flanged 4" cages

Size	Connection	B	E
1"	NPT/SW - 150/300/600 lbs	82 (3.23)	178 (7.00)
1" 1/2"	NPT/SW - 150/300/600 lbs	94 (3.70)	178 (7.00)
2"	NPT/SW - 150/300/600 lbs	97 (3.82)	178 (7.00)
1"	NPT - 900/1500 lbs	92 (3.62)	205 (8.07)
1" 1/2"	NPT - 900/1500 lbs	94 (3.70)	215 (8.46)
2"	NPT - 900/1500 lbs	97 (3.82)	225 (8.86)
1"	NPT - 2500 lbs	99 (3.90)	275 (10.83)
1" 1/2"	NPT - 2500 lbs	102 (4.02)	285 (11.22)
2"	NPT - 2500 lbs	112 (4.41)	295 (11.61)
1"	SW - 900/1500 lbs	99 (3.90)	205 (8.07)
1" 1/2"	SW - 900/1500 lbs	102 (4.02)	215 (8.46)
2"	SW - 900/1500 lbs	112 (4.41)	225 (8.86)
1"	SW - 2500 lbs	99 (3.90)	275 (10.83)
1" 1/2"	SW - 2500 lbs	102 (4.02)	285 (11.22)
2"	SW - 2500 lbs	112 (4.41)	295 (11.61)
1"	RF Slip on flange - 150/300/600 lbs	185 (7.28)	178 (7.00)
1" 1/2"	RF Slip on flange - 150/300/600 lbs	200 (7.87)	178 (7.00)
2"	RF Slip on flange - 150/300/600 lbs	200 (7.87)	178 (7.00)
1"	RJ Weld Neck flange - 600 lbs	185 (7.28)	178 (7.00)
1" 1/2"	RJ Weld Neck flange - 600 lbs	200 (7.87)	178 (7.00)
2"	RJ Weld Neck flange - 600 lbs	200 (7.87)	178 (7.00)
1"	RJ Weld Neck flange - 900 lbs	195 (7.68)	190 (7.48)
1" 1/2"	RJ Weld Neck flange - 900 lbs	205 (8.07)	190 (7.48)
2"	RJ Weld Neck flange - 900 lbs	225 (8.86)	190 (7.48)
1"	RJ Weld Neck flange - 1500 lbs	195 (7.68)	205 (8.07)
1" 1/2"	RJ Weld Neck flange - 1500 lbs	205 (8.07)	205 (8.07)
2"	RJ Weld Neck flange - 1500 lbs	225 (8.86)	205 (8.07)
1"	RJ Weld Neck flange - 2500 lbs	211 (8.31)	275 (10.83)
1" 1/2"	RJ Weld Neck flange - 2500 lbs	235 (9.25)	275 (10.83)
2"	RJ Weld Neck flange - 2500 lbs	250 (9.84)	275 (10.83)
DN 25	PN 16/25/40 flange EN 1092-1 Type B1	185 (7.28)	178 (7.00)
DN 40	PN 16/25/40 flange EN 1092-1 Type B1	200 (7.87)	178 (7.00)
DN 50	PN 16 flange EN 1092-1 Type B1	200 (7.87)	178 (7.00)
DN 50	PN 25/40 flange EN 1092-1 Type B1	203 (7.99)	178 (7.00)
DN 25	PN 63 flange EN 1092-1 Type B2	203 (7.99)	178 (7.00)
DN 40	PN 63 flange EN 1092-1 Type B2	217 (8.54)	178 (7.00)
DN 50	PN 63 flange EN 1092-1 Type B2	217 (8.54)	178 (7.00)
DN 25	PN 100 flange EN 1092-1 Type B2	203 (7.99)	178 (7.00)
DN 40	PN 100 flange EN 1092-1 Type B2	217 (8.54)	178 (7.00)
DN 50	PN 100 flange EN 1092-1 Type B2	223 (8.78)	178 (7.00)
DN 25	PN 160 DIN 2638 Form E	205 (8.07)	205 (8.07)
DN 40	PN 160 DIN 2638 Form E	219 (8.62)	205 (8.07)
DN 50	PN 160 DIN 2638 Form E	230 (9.06)	205 (8.07)
DN 25	PN 250 DIN 2628 Form E	212 (8.35)	205 (8.07)
DN 40	PN 250 DIN 2628 Form E	235 (9.25)	205 (8.07)
DN 50	PN 250 DIN 2628 Form E	240 (9.45)	205 (8.07)
DN 25	PN 320 DIN 2629 Form E	225 (8.86)	275 (10.83)
DN 40	PN 320 DIN 2629 Form E	243 (9.57)	275 (10.83)
DN 50	PN 320 DIN 2629 Form E	255 (10.04)	275 (10.83)

ECLIPSE 705 TRANSMITTER

Dimensions in mm (inches)

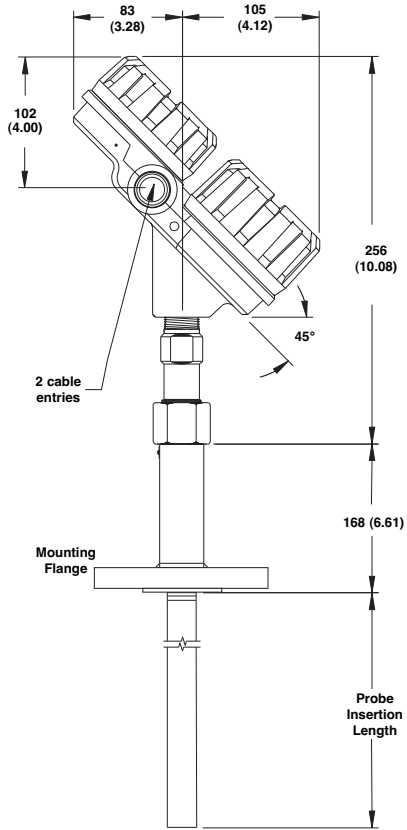

**7MR
with flanged connection**

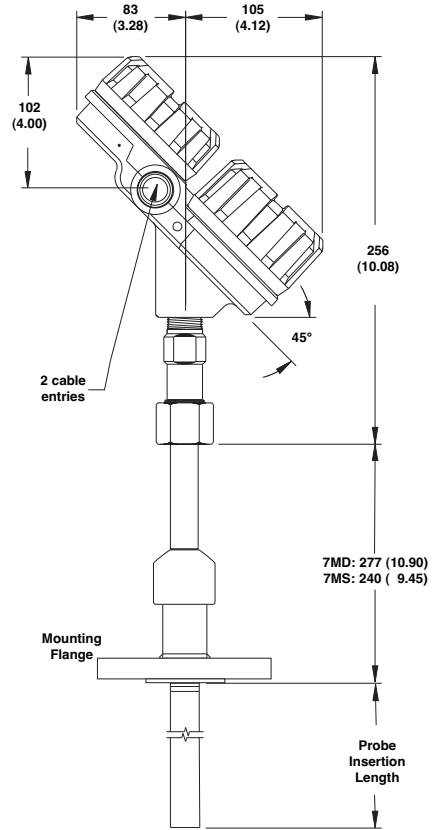

**7MD/7MS
with flanged connection**

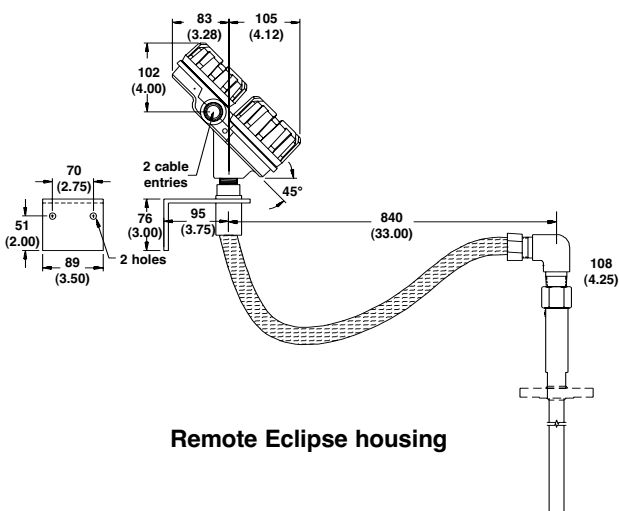

Remote Eclipse housing

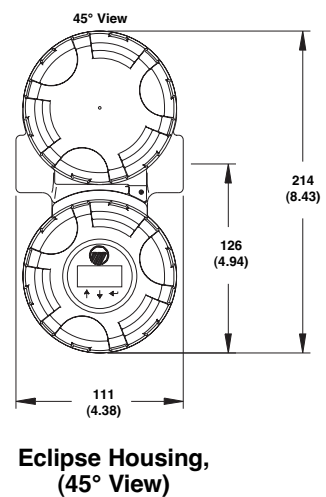

**Eclipse Housing,
(45° View)**

TRANSMITTER SPECIFICATIONS

FUNCTIONAL/PHYSICAL

Description		Specification
Power (at terminals)		General Purpose / ATEX Intrinsically Safe: 11 to 28,6 V DC ATEX Explosion Proof (with Intrinsically Safe probe) 11 to 36 V DC Foundation Fieldbus (FISCO ATEX Exi): 9 to 17,5 V DC Foundation Fieldbus (General purpose & Exd): 9 to 32 V DC
Signal Output		4-20 mA with HART®, 3,8 mA to 20,5 mA useable (meets NAMUR NE 43) or Foundation Fieldbus H1 (ITK Ver. 4)
Span		300 to 5700 mm (12 to 224") (7MS: max 4100 mm (161"))
Resolution		Analog: 0,01 mA Display: 0,1 cm (inch)
Loop Resistance		630 Ω @ 20,5 mA - 24 V DC
Damping		Adjustable 0-10 s
Diagnostic Alarm		Adjustable 3,6 mA, 22 mA, HOLD
User Interface		3-button keypad and/or HART® communicator, Foundation Fieldbus, AMS® or PACTware®
Display		2-line x 8-character LCD
Menu Language		English/Spanish/French/German
Housing Material		IP 66/Aluminium A356T6 (< 0.20 % copper) or stainless steel
Approvals		ATEX II 1 G EEx ia II C T4, intrinsically safe – for non Foundation Fieldbus units FISCO ATEX, intrinsically safe - for Foundation Fieldbus units ATEX II 1/2 G D EEx d[ia] II C T6 - T85 °C, explosion proof for all units ^① ATEX II 3 G EEx nA II T6, non sparking – for non Foundation Fieldbus units FM and CSA, Non incendive, intrinsically safe (FISCO) and explosion proof STOOMWEZEN – Secondary level safety device for steamdrums TÜV – WHG § 19, VLAREM II 5.17-7 LRS – Lloyds Register of Shipping (marine applications) GOST-K/GGTN-K – RoSTECH/FSTS – Russian Authorisation Standards
SIL (Safety Integrity Level)	Standard electronics	Functional safety to SIL 1 / SIL 2 in accordance to 61508 – SFF > 85 % – full FMEDA reports and declaration sheets available at request
	Enhanced electronics	Functional safety to SIL 2 / SIL 3 in accordance to 61508 – SFF > 91 % – full FMEDA reports and declaration sheets available at request
Electrical Data		Ui = 28,4 V, Ii = 94 mA, Pi = 1 W Ui = 17,5 V, Ii = 380 mA, Pi = 5,32 W (Foundation Fieldbus)
Equivalent Data		Ci = 2,2 nF, Li = 3 μH Ci = 0,24 nF, Li = 3 μH (Foundation Fieldbus)
Shock/Vibration Class		ANSI/ISA-571.03 SA1 (Shock), ANSI/ISA-571.03 VC2 (Vibration)
Net and Gross Weight	Cast aluminium	2,70 kg net; 3,20 kg gross – amplifier only
	Stainless steel	5,70 kg net; 6,20 kg gross – amplifier only
Overall Dimensions		H 214 mm (8.43") x W 111 mm (4.38") x D 188 mm

^① ATEX, explosion proof units use EEx d bushing material STYCAST 2057 FR

PERFORMANCE

Description		Specification
Reference Conditions with a 1,8 m (72") coaxial type GWR probe		Reflection from liquid, with dielectric in center of selected range, at +20 °C (70 °F) with CFD threshold ^①
Linearity ^②	Coaxial/twin lead probes	< 0,1 % of probe length or 2,5 mm (0.1"), whichever is greater
	Single lead probes	< 0,3 % of probe length or 8 mm (0.3"), whichever is greater
Accuracy ^②	Coaxial/twin lead probes	< 0,1 % of probe length or 2,5 mm (0.1"), whichever is greater
	Single lead probes	± 0,5 % of probe length or 13 mm (0.5"), whichever is greater
	7MT interface	± 25 mm (1")
Resolution		± 2,5 mm (0.1")
Repeatability		< 2,5 mm (0.1")
Hysteresis		< 2,5 mm (0.1")
Response Time		< 1 second
Warm-up Time		< 5 seconds
Ambient Temp.		-40 °C to +80 °C (-40 °F to +175 °F) – blind transmitter -20 °C to +70 °C (-5 °F to +160 °F) – with digital display -40 °C to +70 °C (-40 °F to +160 °F) – for EEx ia and EEx d[ia] with blind transmitter -20 °C to +70 °C (-5 °F to +160 °F) – for EEx ia and EEx d[ia] with digital display
Process Dielectric Effect		< 7,5 mm (0.3") within selected range
Operating Temp. Effect		Approx. +0,02 % of probe length/°C for probes ≥ 2,5 m (8") ^③
Humidity		0-99 %, non-condensing
Electromagnetic Compatibility		Meets CE requirements (EN-61000-6-4, EN 61000-6-2) and NAMUR NE 21 (Single and Twin-Rod probe must be used in metallic vessel or stillwell)

^① May degrade for 7MD probe or with fixed threshold.

^② Top 600 mm (24") of twin rod probe: 30 mm (1.18").
Top 1220 mm (48") of single rod: application dependant.

^③ Accuracy may degrade slightly < 2,5 m (8')

PROBE SPECIFICATIONS

Description		7MR: overfill safe GWR probe
Materials	Probe	316/316L (1.4401/1.4404) Hastelloy C® (2.4819) or Monel® (2.4360)
	Process seal	Viton® GFLT, EPDM or Kalrez 4079 (Consult factory for alternatives)
Probe diameter		Inside rod: 8 mm (0.3125") – Outer tube: 22 mm (0.875")
Mounting		In-tank mounting / external cage mounting (WHG approved)
Process Connection		Threaded: 3/4" NPT or 1" BSP (G1) Flanged: Various ANSI, EN/DIN or torque tube mating flanges
Probe length		From 600 mm to 6100 mm (24 to 240"), selectable per 10 mm
Transition Zone ^①	Top	0 mm (0")
	Bottom	εr: 2,0 = 150 mm (6")/εr: 80 = 25 mm (1")
Max. Process Temp.		+200 °C @ 18 bar (+400 °F @ 270 psi)
Max. Process Pressure		70 bar @ +20 °C (1000 psi @ +70 °F) – see table at page 11
Dielectric Range – Max. Viscosity		1,4 to 100 – 200 cP

Viton® is a registered trademark of Dupont Performance Elastomers

Description		7MD: high pressure/high temperature GWR probe (overfill safe)	7MS: saturated steam GWR probe (overfill safe)
Materials	Probe	316/316L (1.4401/1.4404)	
	Process seal	Borosilicate/inconel X750	PEEK with Aegis PF 128
	Spacers	Ceramic	
Probe diameter		Inside rod: 8 mm (0.125") – Outer tube: 22 mm (0.875")	
Mounting		In-tank mounting / external cage mounting (7MD – WHG / 7MS – Stoomwezen approved)	
Process Connection		Threaded: 3/4" NPT or 1" BSP (G1) Flanged: Various ANSI, EN/DIN or "proprietary" mating flanges	
Probe length (selectable per 10 mm)		From 600 mm to 6100 mm (24 to 240")	From 1100 mm to 4500 mm (43 to 177")
Transition Zone ^①	Top	25 mm (1")	
	Bottom	εr: 2,0 = 150 mm (6") / εr: 80 = 25 mm (1")	εr: 10 = 150 mm (6") / εr: 80 = 25 mm (1")
Process Temp.	Max	+400 °C @ 135 bar (+750 °F @ 2000 psi)	+345 °C @ 155 bar (+650 °F @ 2250 psi)
	Min	-196 °C @ 135 bar (-320 °F @ 2000 psi)	-15 °C @ 205 bar (0 °F @ 3000 psi)
Max. Process Pressure		345 bar @ +20 °C (5000 psig @ +70 °F)	155 bar @ +345 °C (2250 psi @ +650 °F)
Max. Viscosity		200 cP	
Dielectric Range		2 to 100	10 to 100
Vacuum service		Full vacuum (Helium leak < 10 ⁻⁸ cc/s @ 1 atmosphere vacuum)	Negative pressure but not up to full vacuum

MAGNETIC LEVEL INDICATOR – SPECIFICATIONS

Measured value	Liquid level (consult factory for liquid-liquid interface)	
Measuring range	From 300 mm (11.81") up to 5700 mm (224")	
Indicators	Metal flag (red/white) – all indicators are hermetically sealed and assured by the "Insta-Seal" technology	
Scale	In cm or % of span	
Specific gravity	As low as 0.5 kg/dm ³	
Visual indication	Visible from a distance up to 30 m (100 feet)	
Float	Type	With magnetic flux ring – assembly – see page 2
	Materials	316 SST (1.4401), Titanium, others at request
Cage	Materials	316/316L SST (1.4401/1.4404), others at request
	Size	3" or 4" depending configuration
	Rating	Up to 2500 lbs / PN 320 class ratings
	Configuration	Side/side connection with 1/2" NPT plugged vent and drain
Insulation material	Weather resistant silicone cloth (high temperature application) Polyurethane + aluminium jacket with polymeric frost extension for flag-rail (cryogenic application)	
Process connections	Threaded, socket welded or flanged	
Design	All cages are designed to meet the European PED (Pressure Equipment Directives) 97/23 EC guidelines	
Constructions	Standard commercial design NACE construction Others at request: eg. IBR, ASME - ANSI B31.3	

TEMPERATURE-PRESSURE RATING FOR ECLIPSE PROBE SEALS

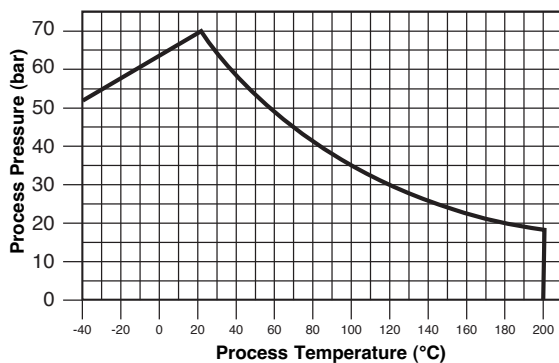

———— 7MR: overfill prevention GWR probe

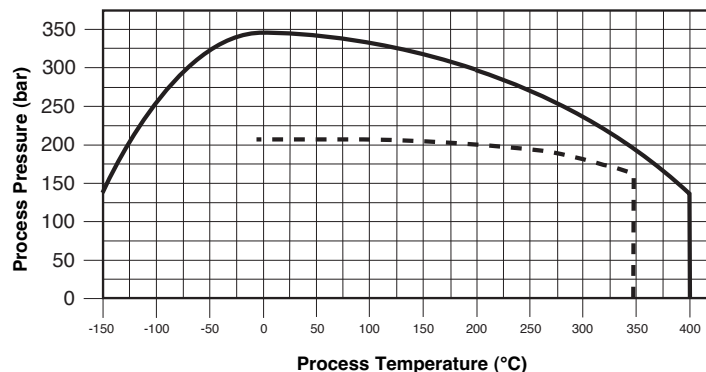

———— 7MD: high temperature / high pressure GWR probe
 - - - - 7MS: saturated steam GWR probe



QUALITY ASSURANCE - ISO 9001:2000

THE QUALITY ASSURANCE SYSTEM IN PLACE AT MAGNETROL GUARANTEES THE HIGHEST LEVEL OF QUALITY DURING THE DESIGN, THE CONSTRUCTION AND THE SERVICE OF CONTROLS. OUR QUALITY ASSURANCE SYSTEM IS APPROVED AND CERTIFIED TO **ISO 9001:2000** AND OUR TOTAL COMPANY IS COMMITTED TO PROVIDING FULL CUSTOMER SATISFACTION BOTH IN QUALITY PRODUCTS AND QUALITY SERVICE.

PRODUCT WARRANTY

ALL MAGNETROL MECHANICAL LEVEL CONTROLS ARE WARRANTED FREE OF DEFECTS IN MATERIALS AND WORKMANSHIP FOR FIVE FULL YEARS (ELECTRONICS ONE FULL YEAR) FROM THE DATE OF ORIGINAL FACTORY SHIPMENT.

IF RETURNED WITHIN THE WARRANTY PERIOD; AND, UPON FACTORY INSPECTION OF THE CONTROL, THE CAUSE OF THE CLAIM IS DETERMINED TO BE COVERED UNDER THE WARRANTY; THEN, MAGNETROL INTERNATIONAL WILL REPAIR OR REPLACE THE CONTROL AT NO COST TO THE PURCHASER (OR OWNER) OTHER THAN TRANSPORTATION.

MAGNETROL SHALL NOT BE LIABLE FOR MISAPPLICATION, LABOR CLAIMS, DIRECT OR CONSEQUENTIAL DAMAGE OR EXPENSE ARISING FROM THE INSTALLATION OR USE OF THE EQUIPMENT. THERE ARE NO OTHER WARRANTIES EXPRESSED OR IMPLIED, EXCEPT, SPECIAL WRITTEN WARRANTIES COVERING SOME MAGNETROL PRODUCTS.



BULLETIN N°: BE 57-138.3
EFFECTIVE: NOVEMBER 2005
SUPERSEDES: December 2002

UNDER RESERVE OF MODIFICATIONS

BENELUX	Heikensstraat 6, 9240 Zele, België Tel. +32 (0)52.45.11.11 • Fax. +32 (0)52.45.09.93 • E-Mail: info@magnetrol.be
DEUTSCHLAND	Alte Ziegelei 2-4, D-51491 Overath Tel. 02204 / 9536-0 • Fax. 02204 / 9536-53 • E-Mail: vertrieb@magnetrol.de
FRANCE	40 - 42, rue Gabriel Péri, 95130 Le Plessis Bouchard Tel. 01.34.44.26.10 • Fax. 01.34.44.26.06 • E-Mail: magnetrolfrance@magnetrol.fr
ITALIA	Via Arese 12, I-20159 Milano Tel. (02) 607.22.98 (R.A.) • Fax. (02) 668.66.52 • E-Mail: mit.gen@magnetrol.it
UNITED KINGDOM	Unit 1 Regent Business Centre, Jubilee Road Burgess Hill West Sussex RH 15 9TL Tel. (01444) 871313 • Fax (01444) 871317 • E-Mail: sales@magnetrol.co.uk
INDIA	E-22, Anand Niketan, New Delhi - 110 021 Tel. 91 (11) 51661840 • Fax 91 (11) 51661843 • E-Mail: info@magnetrolindia.com

www.magnetrol.com

OUR NEAREST REPRESENTATIVE