



## M-Series Analog Level Gauges

Form 1110

### Liquid Level, Interface and Temperature Measurement

SOR M-Series liquid level gauges offer unsurpassed flexibility to meet most process application conditions. M-series gauges are modular in design, offering a selection of electronics housing styles, sensor pipe styles, and materials of construction.

The M-Series gauge features a flexible, removable sensing element. At any time, the sensor element and electronics housing may be removed from the sensor pipe without disturbing the process operation.

Up to two 4 to 20mA loops are available for analog indication of level, interface and temperature. HART® communication allows the M-Series gauge to simultaneously indicate and display all three measurement variables.

Set-up, calibration and diagnostics are available from any point in the loop using a standard HART hand-held terminal. An optional on-board display and keypad is also provided for local indication and programming.

The M-Series gauges can incorporate an RTD for spot temperature measurement of your process. Rigid gauges are available in lengths up to 20 feet.

All SOR gauges use magnetostrictive technology and have only one moving part – the float. This simple design ensures that no scheduled maintenance or recalibration will be required.

#### Features

- Modular design
- High accuracy and repeatability
- Two-channel output
- Multidrop HART® communication
- Explosion-proof and/or intrinsically safe (model dependent)
- -40°F to 300°F temperature range
- No maintenance required

#### Applications

- Process level measurement
- Interface measurement
- Temperature measurement

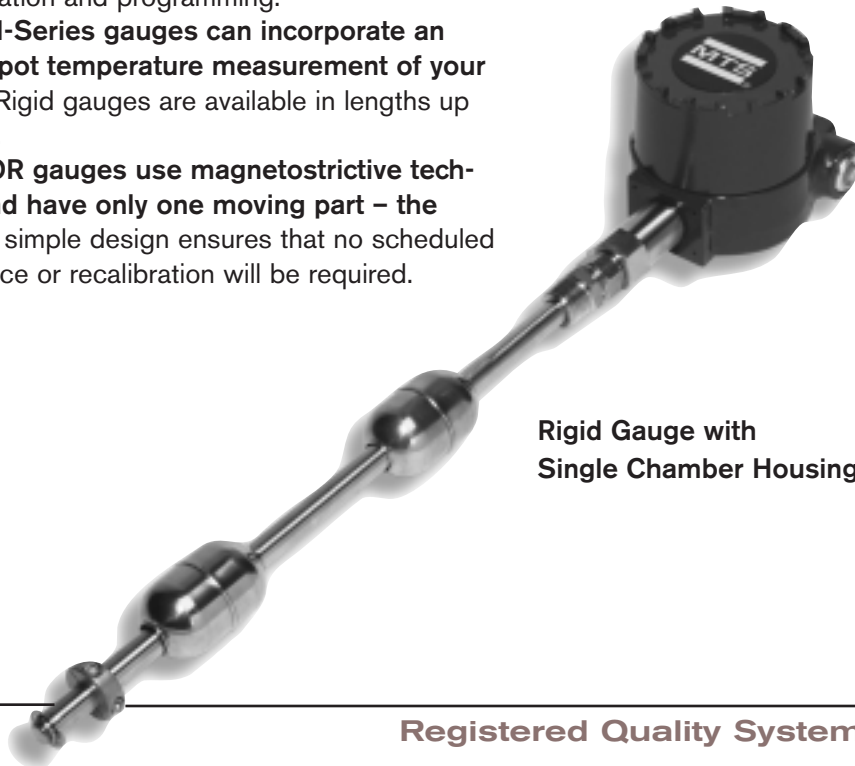

Rigid Gauge with  
Single Chamber Housing

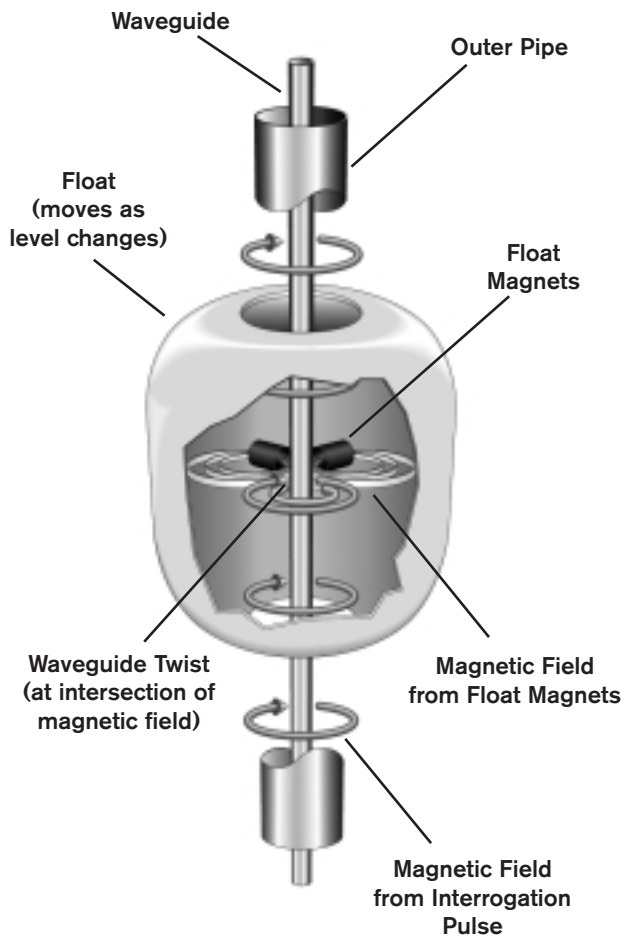

### Magnetostrictive Technology

The liquid level gauge is composed of three concentric members. The outermost member is a protective, product-compatible outer pipe that withstands aggressive or harsh process industry applications. The middle member has a resistive temperature device (RTD) mounted on it for an accurate temperature measuring. The heart of the gauge design is the innermost member – the waveguide – a formed element constructed of a proprietary magnetostrictive material.

A low current interrogation pulse is generated in the gauge electronics and transmitted down the waveguide creating an electromagnetic field along its length. When this magnetic field interacts with the permanent magnetic field of a magnet mounted inside the float, a torsional strain pulse (or waveguide twist) results. This waveguide twist is detected as a return pulse. The time period between the initiation of the interrogation pulse and the detection of the return pulse is used to determine the level measurement with a high degree of accuracy and reliability.

### Agency Approvals



<b>Agency Approval</b>	FM Explosion-proof Class I, Groups B, C, D Class II, Groups E, F, G Division 1, NEMA 4X	FM Intrinsically Safe** Class 1, Groups A, B, C, D Class II, Groups E, F, G Division 1, NEMA 4X
<b>Models</b>	Explosion-proof housing required	All



<b>Agency Approval</b>	CSA Explosion-proof Class I, Groups B, C, D Class II, Groups E, F, G Division 1, NEMA 4X	CSA Intrinsically Safe** Class 1, Groups A, B, C, D Class II, Groups E, F, G Division 1, NEMA 4X
<b>Models</b>	Explosion-proof housing required	All

\*\* When installed with approved I.S. barriers.

## Product Specifications

### Level Output

Measured Variable	Liquid level, interface level, temperature
Output	4-20mA, 2 loops with HART
Full Range	18 to 240 inches (46 to 609 cm)
Non-Linearity	0.020% F.S. (Independent BSL) or 1/32 inches (0.794 mm)*
Repeatability	0.005% F.S. or 0.005 inches (0.127 mm)*
Sensor Operating Temperature	-40 to 300°F (-40 to 149°C)

### Gauge Loop

Input Voltage Range	10.5 to 36.1 Vdc
Reverse Polarity Protection	Series diodes
Transient Protection	Stage 1: line-to-ground surge suppressors; 2500 amps peak (8/20 µsec.)  Stage 2: line-to-line and line-to-ground transient suppressors; 1500 watts peak (10/1000 µsec.)

### Calibration

Zero Adjust Range	Anywhere within the active length.
Span Adjust Range	Full scale $\geq$ 0.5 feet (152 mm) from zero

### Temperature Output

Type	4-20mA from 1,000Ω platinum RTD at 0°C
Repeatability	$\pm 0.18^\circ\text{F}$ (0.1°C)
Accuracy	$\pm 2.7^\circ\text{F}$ ( $\pm 1.5^\circ\text{C}$ )
Drift	$\pm 0.9^\circ\text{F}$ (0.5°C) per year
Zero Adjust	-40 to 255°F (-40 to 124°C)
Span Adjust	45°F (7.2°C) minimum, full scale (maximum) = 300°F (149°C)

### Environmental

Humidity	0 to 100% R.H., non-condensing
Electronics Operating Temperature	-30 to 160°F (-34 to 71°C)
Vessel Pressure	Dependent on float pressure rating
Materials (wetted parts)	316L stainless steel, Hastelloy C-276, Monel K-400 and Teflon®

### Field Installation

Mounting	3/4-inch NPT fitting or flange mounting
Wiring	2-wire connection, shielded cable or twisted pair to screw terminals through a 3/4-inch NPT conduit opening.

### Display (optional)

Zero Adjust Range	Anywhere within the active length.
Span Adjust Range	Full scale $\geq$ 0.5 feet (152 mm) from zero

### Temperature Output

Measured Variables	Level 1, Level 2, temperature
Update Rate	3 second
Size	0.5 inch (12.7 mm)
Number of Digits	16

### HART® Communications

Method of Communication	Frequency Shift Keying (FSK) conforms with Bell 202 modem standard with respect to baud rate and digital "1" and "0" frequencies.
Baud Rate	1200 bps
Digital "0" Frequency	2200 Hz
Digital "1" Frequency	1200 Hz
Data Byte Structure	1 start bit, 8 data bits, 1 odd parity bit, 1 stop bit
Digital Process Variable Rate	Poll/response model 2.0 per second

\* Whichever is greater.

All specifications are subject to change without notice. Consult SOR for verification of specifications critical to your needs.

## Model Numbering System



### 1 Model

**M** Magnetostrictive gauge

### 2 Type

**R** Transmitter

### 3 Input Power

**A** 24 Vdc, 2-wire loop (intrinsically safe)

### 4 Output

**1** 4-20mA single loop with HART

**2** 4-20mA dual loops with HART

### 5 Housing Type

**B** Single cavity (explosion-proof)

**D** Single cavity with display (explosion-proof)

### 6 Electronics Mounting

**1** Integral electronics

### 7 Sensor Pipe

**B** Industrial end plug with stop collar

### 8 Construction Material (wetted parts)

**1** 316L stainless steel

**3** Hastelloy C-276

**4** Monel K-400

**A** Teflon® (FEP, 15 psi@100° maximum)

### 9 Process Connection Type

**1** NPT, adjustable

**6** 316L stainless steel only

**6** 150# welded RF flange\*

**7** 300# welded RF flange\*

**8** 600# welded RF flange\*

**X** None

### 10 Process Connection Size

**A** 3/4-inch NPT

**D** 2-inch

**F** 3-inch

**G** 4-inch

**H** 5-inch

**J** 6-inch

### 11 RTD

**0** None

**1** One RTD, fixed position  
(3 inches from gauge tip)

**2** One RTD, customer-defined position

### 12 Unit of Measurement

**M** Metric (centimeters)

**U** US Customary (inches)

### 13, 14, 15, 16, 17 Length

Order length based on unit of measurement.

Encode length in inches for US Customary.

Encode length in centimeters if using metric.

**Rigid sensor pipe:** 18 - 240 inches  
(46 - 609 cm)

### 18 Special

**S** Standard product

**E** Engineering special  
(not affecting agency-controlled parts or features)

\* Shipping crate required. Additional charges apply.

### Typical Product Installation

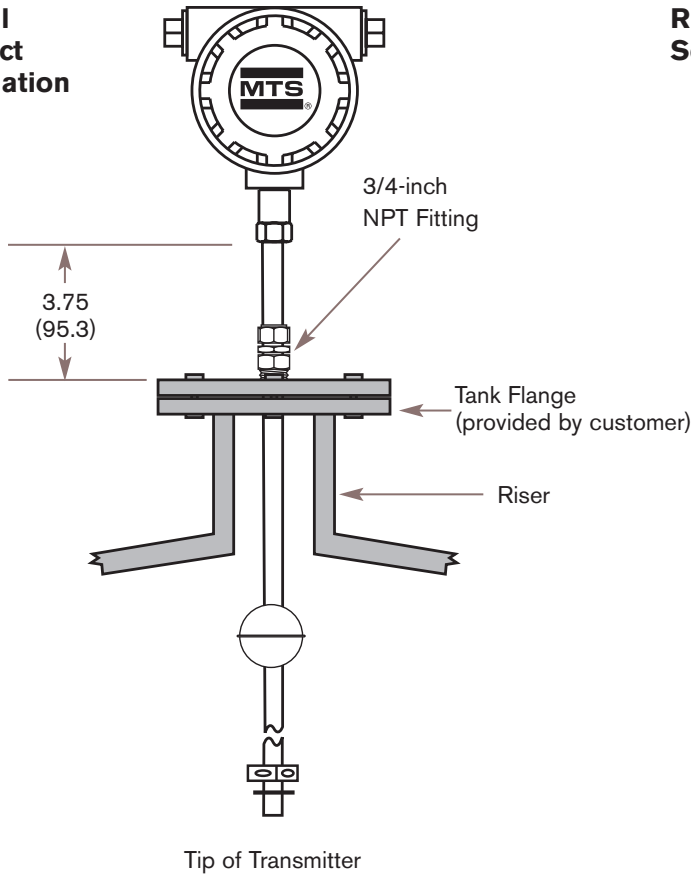

### Rigid Sensor Pipe

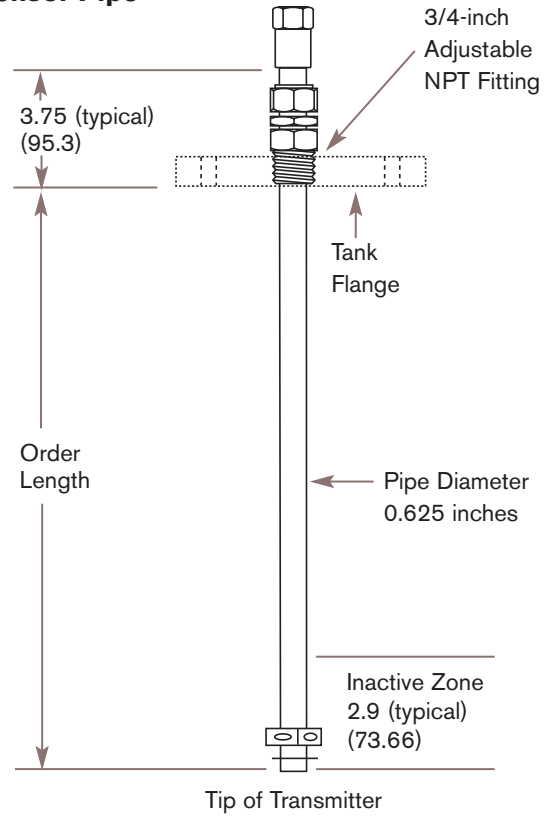

### Single Chamber Enclosure

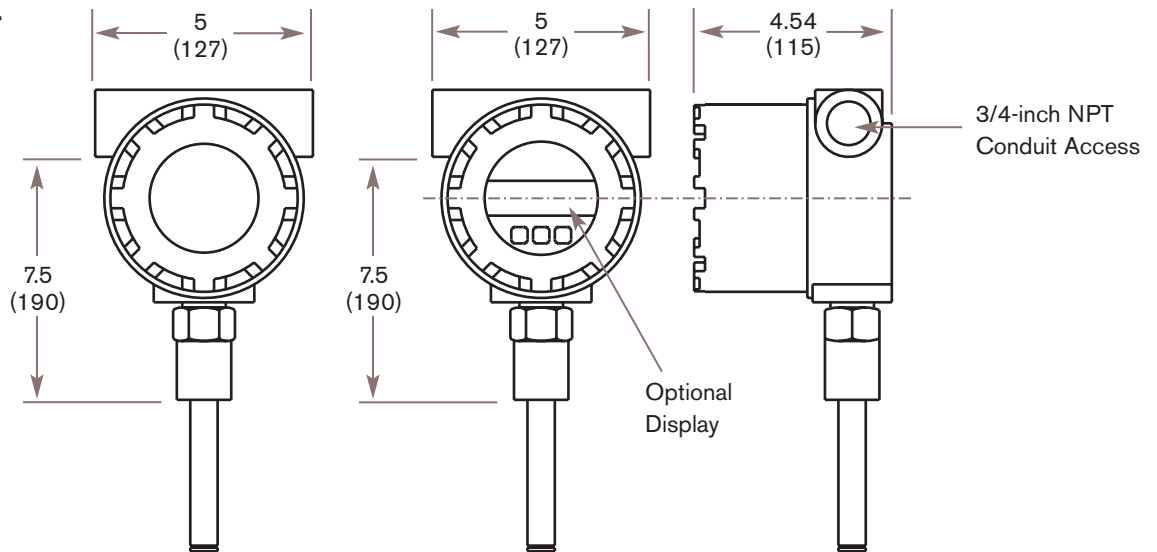

Linear = in (mm)

Design and specifications are subject to change without notice.