

DESCRIPTION

EZ Modulelevel are electronic 24 V DC, loop powered level transmitters utilizing Magnetrol's buoyancy principle to detect and convert liquid level changes into a stable 4-20 mA output signal.

The linkage between the level sensing element and output electronics greatly simplifies mechanical design and construction. The in-line vertical design of the transmitter reduces instrument weight and the effects of process vibration on electronic circuitry components while simplifying installation.

FEATURES

- Operation functions include:
 - interface measurement and detection
 - continuous level measurement
 - density measurement
- Easy bench calibration via Hart[®] terminal or AMS[®] protocol
 - full calibration (dry set point, 4/20 mA by %)
 - setting of Specific Gravity
 - signal damping
 - error signal.
- Two-wire, intrinsically safe loop powered level transmitter.
- 360° rotatable housing can be dismantled without depressurizing the vessel.
- Integral or remote electronics.
- Special options, materials and custom engineered features.
- Suited for SIL 1 and SIL 2 loops (full FMEDA report available).



APPLICATIONS

MEDIA: liquids with a S.G. as low as 0,23 up to 2,2 and interfaces with a density difference of minimum 0,10.

VESSELS: most process vessels up to 315 °C (600 °F) process temperature and pressures up to 355 bar (5150 psi) or storage vessels e.g:

- feedwater heaters
- condensate Drip Pots
- scrubbers
- separators
- receivers
- flash tanks
- knock out drums
- boilers

For continuous level and/or interface



AGENCY APPROVALS

Agency	Approval
ATEX	II 1G EEx ia II C T6, intrinsically safe II 1/2G EEx d II C T6, explosion proof
FM/CSA [®]	Explosion proof and intrinsically safe
GOST/ GOSGORTECHNADZOR [®]	Russian Authorisation Standards

[®] Consult factory for proper partnumbers.

PRINCIPLE OF OPERATION

Liquid level change acts upon the range spring supported displacer causing vertical motion of a core within a linear variable differential transformer (LVDT). The enclosing tube acts as a static isolation barrier between the LVDT and the process media. As core position changes with liquid level, voltages are induced in the secondary windings of the LVDT. These signals are processed in the electronic circuitry and used to control the current in the 4-20 mA output current loop.

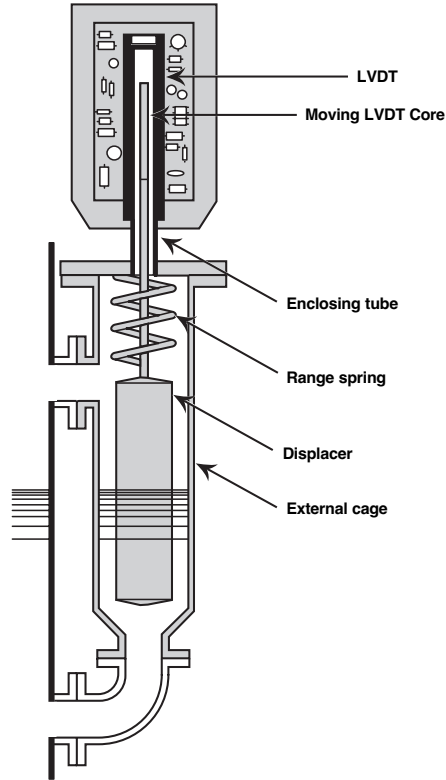

MOUNTING

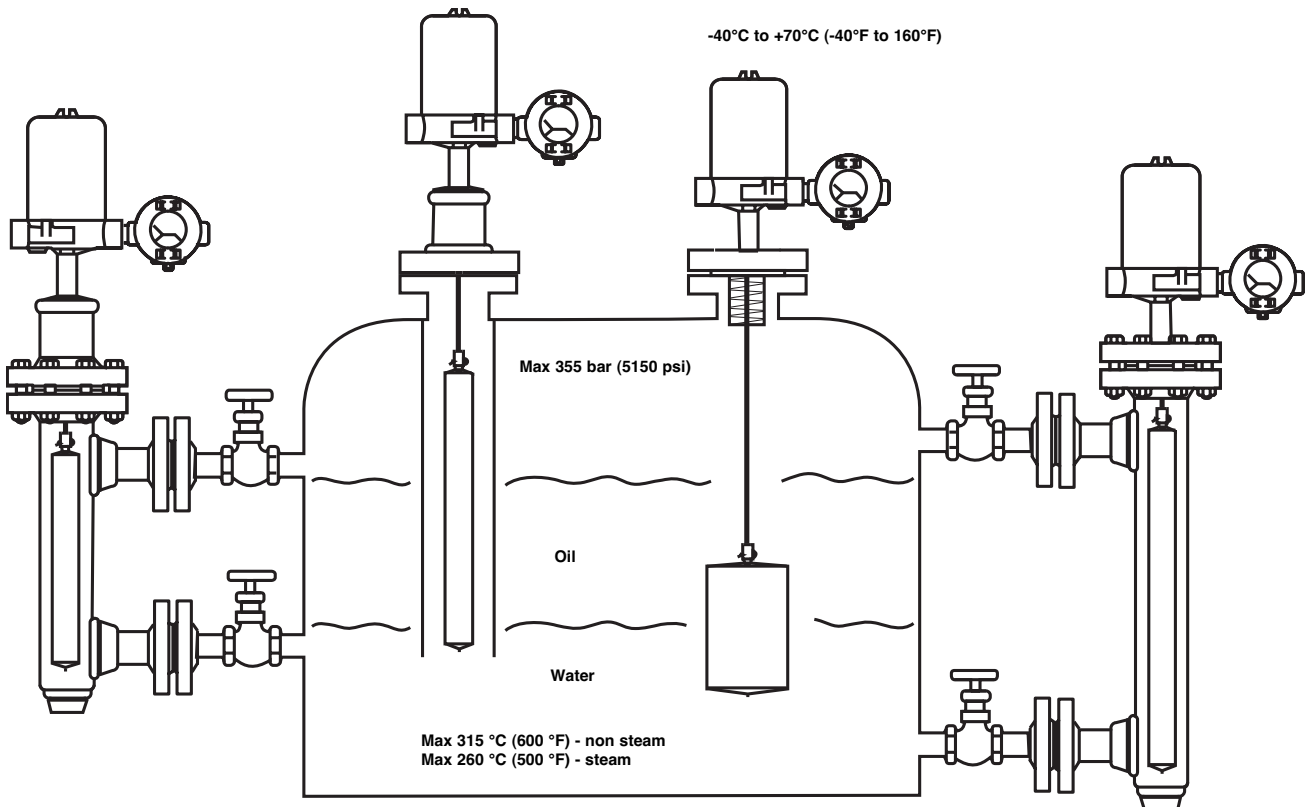

EXPEDITE SHIP PLAN (ESP)

Several EZ Modulelevel devices are available for quick shipment, within max. 3 weeks after factory receipt of purchase order, through the Expedite Ship Plan (ESP).

Models covered by ESP service are conveniently grey coded in the selection data charts.

To take advantage of ESP, simply match the grey coded model number codes (standard dimensions apply).

ESP service may not apply to orders of ten units or more. Contact your local representative for lead times on larger volume orders, as well as other products and options.

SELECTION DATA

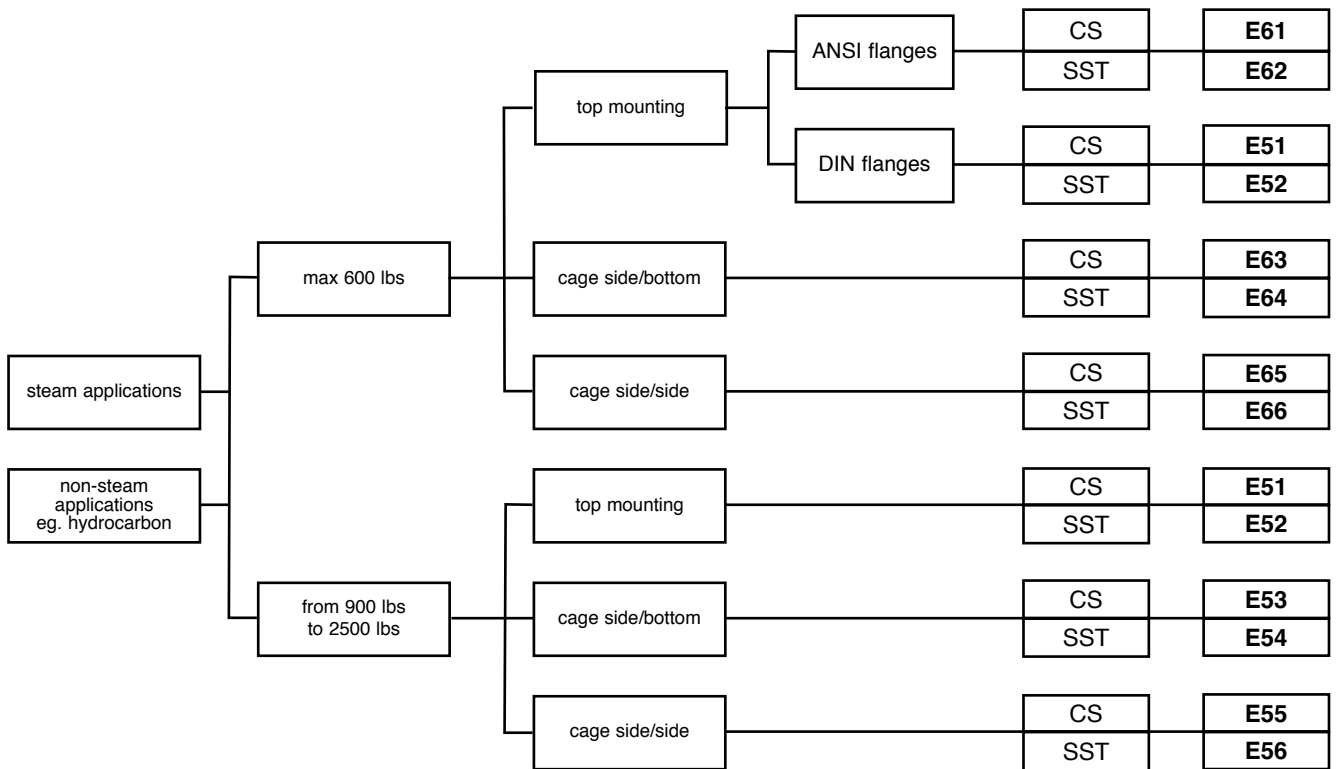

CONFIGURATIONS

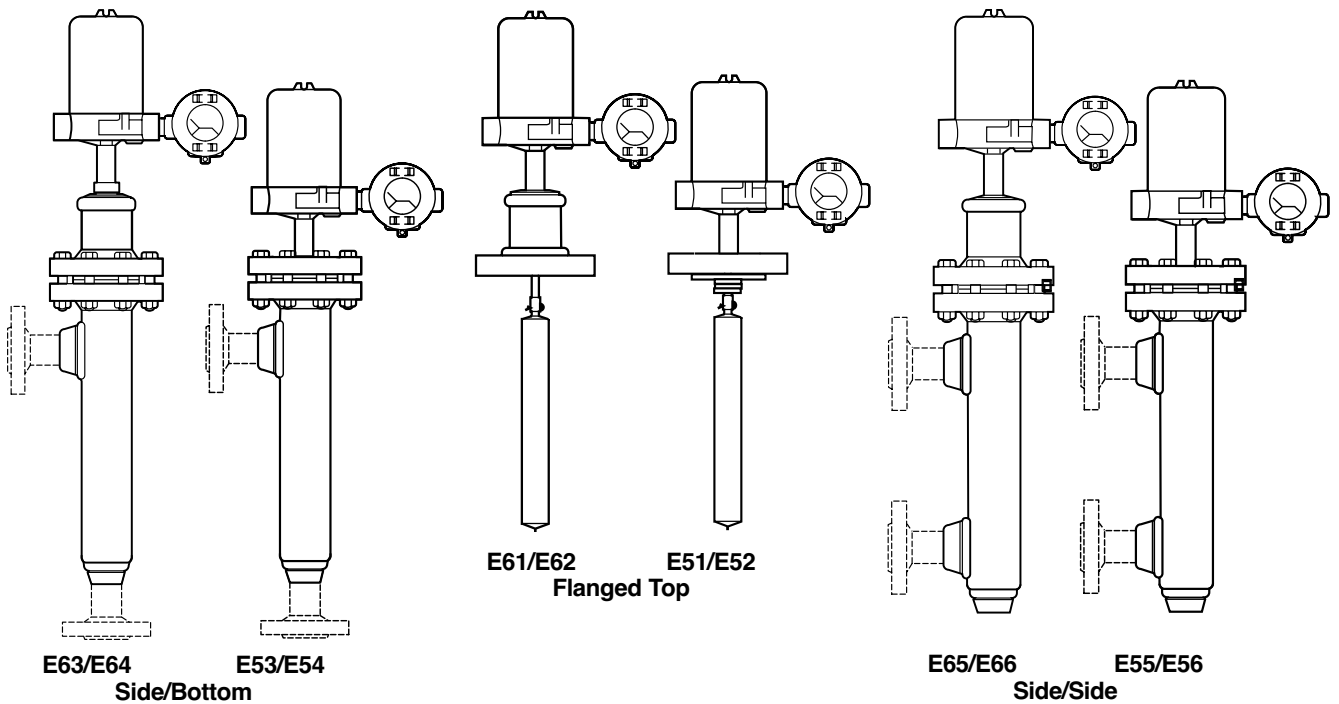

SELECTION DATA - Options:

- 1 Adjustable displacer hanger. order code **032-3110-004** (standard length 2.5 m [8']) – required when distance between top displacer and mounting flange is > 236 mm (9.31").
- 2 Calibraton stand for bench calibration, order code **031-6107-001**.
- 3 HAND HELD communicator, consult factory.

SELECTION DATA – non steam applications (max 600 lbs)

A complete measuring system consists of:

- One order code for a complete standard EZ Modulelevel® transmitter.
Order code for modified models/adders or units with a digital meter: put an "X" in front of the closest matching order code and specify the modification/adders separately.
e.g: XE63-KC5A-ESD X = material certification EN 10204 / DIN 50049-3.1.B
- Options - see page 3

1. Order code for Standard EZ Modulelevel® transmitter – non steam applications

BASIC MODEL NUMBER

E 5 1	top mounted EZ Modulelevel with DIN Flange	- Carbon steel construction
E 5 2	top mounted EZ Modulelevel with DIN Flange	- Stainless steel construction
E 6 1	top mounted EZ Modulelevel with ANSI Flange	- Carbon steel construction
E 6 2	top mounted EZ Modulelevel with ANSI Flange	- Stainless steel construction
E 6 3	EZ Modulelevel with side/bottom cage	- Carbon steel construction
E 6 4	EZ Modulelevel with side/bottom cage	- Stainless steel construction
E 6 5	EZ Modulelevel with side/side cage	- Carbon steel construction
E 6 6	EZ Modulelevel with side/side cage	- Stainless steel construction

SPECIFIC GRAVITY AND PROCESS TEMPERATURE

integral 150°C	integral 200°C	integral 230°C	integral 290°C	remote 315°C	mounting max. temp.
J	A	M	D	Q	0.23 - 0.54 specific gravity
K	B	N	E	R	0.55 - 1.09 specific gravity
L	C	P	F	T	1.10 - 2.20 specific gravity

TANK CONNECTION

a. For top mounted connection type

E61/E62 - ANSI HEAD Flange rating				E51/E52 - DIN / EN 1092-1 HEAD Flange rating				
RF 150 lbs	RF 300 lbs	RF 600 lbs	Size	Type B1 PN 16	Type B1 PN 40	Type B2 PN 63	Type B2 PN 100	Size
G3	G4	G5	3"	7F	7G	7H	7J	DN 80
H3	H4	H5	4"	8F	8G	8H	8J	DN 100
K3	K4	K5	6"	9F	9G	9H	9J	DN 150

b. For external cage models

E63 ... E66 - ANSI Cage rating				E63 ... E66 - DIN / EN 1092-1 Cage rating				
RF 150 lbs	RF 300 lbs	RF 600 lbs	Size	Type B1 PN 16	Type B1 PN 40	Type B2 PN 63	Type B2 PN 100	Size
C5	C7	C9	1 1/2" NPT	2F	2H	2J	2K	DN 40 flanged
C6	C8	C0	1 1/2" S.W.					
P3	P4	P5	1 1/2" flanged					
D5	D7	D9	2" NPT	3F	3H	3J	3K	DN 50 flanged
D6	D8	D0	2" S.W.					
Q3	Q4	Q5	2" flanged					

LEVEL RANGE

356 14	813 32	1219 48	1524 60	1829 72	2134 84	2438 96	2743 108	3048 120	mm inches
A	B	C	D	E	F	G	H	I	code

TRANSMITTER – ELECTRONICS

INTEGRAL MOUNT ELECTRONICS Max 290 °C (All except Q, R, T)			REMOTE ELECTRONICS Max 315 °C (Q, R or T)			24 V DC amplifier head Process Temperature (codes as per digit 4)	
Blind	with meter		Blind	with meter		Local meter	Output & Safety approvals
	Analog	Digital		Analog	Digital		
ESD	ESI	ESJ	RSQ	RST	RSZ	4 - 20 mA with HART®, intrinsically safe	
ESA	ESG	ES9	RSW	RSX	RS4	4 - 20 mA with HART®, explosion proof	
EZA	EZG	-	RZW	RZX	-	4 - 20 mA, explosion proof	

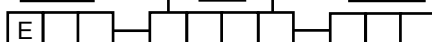

complete order code for EZ Modulelevel transmitter – non steam applications

SELECTION DATA – steam applications (max 600 lbs)

A complete measuring system consists of:

- One order code for a complete standard EZ Modulelevel® transmitter.
Order code for modified models/adders or units with a digital meter: put an "X" in front of the closest matching order code and specify the modification/adders separately.
e.g: XE63-KC5A-ESD X = material certification EN 10204 / DIN 50049-3.1.B
- Options - see page 3

1. Order code for Standard EZ Modulelevel® transmitter – steam applications

BASIC MODEL NUMBER

E 5 1	top mounted EZ Modulelevel with DIN Flange	- Carbon steel construction
E 5 2	top mounted EZ Modulelevel with DIN Flange	- Stainless steel construction
E 6 1	top mounted EZ Modulelevel with ANSI Flange	- Carbon steel construction
E 6 2	top mounted EZ Modulelevel with ANSI Flange	- Stainless steel construction
E 6 3	EZ Modulelevel with side/bottom cage	- Carbon steel construction
E 6 4	EZ Modulelevel with side/bottom cage	- Stainless steel construction
E 6 5	EZ Modulelevel with side/side cage	- Carbon steel construction
E 6 6	EZ Modulelevel with side/side cage	- Stainless steel construction

SPECIFIC GRAVITY AND PROCESS TEMPERATURE

integral 150°C	integral 200°C	integral 230°C	remote 260°C	mounting max. temp.
J	A	M	Q	0.23 - 0.54 specific gravity
K	B	N	R	0.55 - 1.09 specific gravity
L	C	P	T	1.10 - 2.20 specific gravity

TANK CONNECTION

a. For top mounted connection type

E61/E62 - ANSI HEAD Flange rating				E51/E52 - DIN / EN 1092-1 HEAD Flange rating				
RF 150 lbs	RF 300 lbs	RF 600 lbs	Size	Type B1 PN 16	Type B1 PN 40	Type B2 PN 63	Type B2 PN 100	Size
G3	G4	G5	3"	7F	7G	7H	7J	DN 80
H3	H4	H5	4"	8F	8G	8H	8J	DN 100
K3	K4	K5	6"	9F	9G	9H	9J	DN 150

b. For external cage models

E63 ... E66 - ANSI Cage rating				E63 ... E66 - DIN / EN 1092-1 Cage rating				
RF 150 lbs	RF 300 lbs	RF 600 lbs	Size	Type B1 PN 16	Type B1 PN 40	Type B2 PN 63	Type B2 PN 100	Size
C5	C7	C9	1 1/2" NPT	2F	2H	2J	2K	DN 40 flanged
C6	C8	C0	1 1/2" S.W.					
P3	P4	P5	1 1/2" flanged					
D5	D7	D9	2" NPT	3F	3H	3J	3K	DN 50 flanged
D6	D8	D0	2" S.W.					
Q3	Q4	Q5	2" flanged					

LEVEL RANGE

356 14	813 32	1219 48	1524 60	1829 72	2134 84	2438 96	2743 108	3048 120	mm inches
A	B	C	D	E	F	G	H	I	code

TRANSMITTER – ELECTRONICS

INTEGRAL MOUNT ELECTRONICS						REMOTE ELECTRONICS			24 V DC amplifier head	
Max +150 °C (J, K or L)			Max +230 °C (A, B, C, M, N or P)			Max +260 °C (Q, R or T)			Process Temperature (codes as per digit 4)	
Blind	with meter		Blind	with meter		Blind	with meter		Local meter	Output & Safety approvals
	Analog	Digital		Analog	Digital		Analog	Digital		
ESD	ESI	ESJ	ESH	ESK	ES8	RSQ	RST	RSZ	4 - 20 mA with HART®, intrinsically safe	
ESA	ESG	ES9	ESE	ESF	ES7	RSW	RSX	RS4	4 - 20 mA with HART®, explosion proof	
EZA	EZG	-	EZE	EZF	-	RZW	RZX	-	4 - 20 mA, explosion proof	

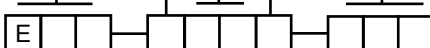

complete order code for EZ Modulelevel transmitter – steam applications

SELECTION DATA – non steam applications (from 900 lbs to 2500 lbs)

A complete measuring system consists of:

- One order code for a complete standard EZ Modulelevel® transmitter.
Order code for modified models/adders or units with a digital meter: put an "X" in front of the closest matching order code and specify the modification/adders separately.
e.g: XE53-KL5A-ESD X = Material certification EN 10204 / DIN 50049-3.1.B
- Options - see page 3

1. Order code for Standard EZ Modulelevel® transmitter – non steam applications / high pressure

BASIC MODEL NUMBER

E 5 1	top mounted EZ Modulelevel	- Carbon steel construction
E 5 2	top mounted EZ Modulelevel	- Stainless steel construction
E 5 3	EZ Modulelevel with side/bottom cage	- Carbon steel construction
E 5 4	EZ Modulelevel with side/bottom cage	- Stainless steel construction
E 5 5	EZ Modulelevel with side/side cage	- Carbon steel construction
E 5 6	EZ Modulelevel with side/side cage	- Stainless steel construction

SPECIFIC GRAVITY AND PROCESS TEMPERATURE

integral 150°C	integral 200°C	integral 230°C	integral 290°C	remote 315°C	mounting max. temp.
K	B	N	E	R	0.55 - 1.09 specific gravity

TANK CONNECTION (for DIN flanges consult factory)

a. For top mounted connection type (E51, E52) - head flange rating

RJ900 lb	RJ 1500 lb	RJ 2500 lb	RF: raised face - RJ: ring joint
H7	H8	H9	4" size
K7	K8	K9	6" size

b. For external cage models (E53, E54, E55, E56) - ANSI cage rating

RJ900 lb	RJ 1500 lb	RJ 2500 lb	connection
L5	L7	L9	1 1/2" NPT
M5	M7	M9	1 1/2" socket weld
P7	P8	P9	1 1/2" ANSI flanges
L6	L8	L0	2" NPT
M6	M8	M0	2" socket weld
Q7	Q8	Q9	2" ANSI flanges

LEVEL RANGE (consult factory for longer level range)

356	813	1219	1524	mm
14	32	48	60	inches
A	B	C	D	code

TRANSMITTER – ELECTRONICS

INTEGRAL MOUNT ELECTRONICS Max 290 °C (K, B, N or E)			REMOTE ELECTRONICS Max 315 °C (R only)			24 V DC amplifier head Process Temperature (codes as per digit 4)	
Blind	with meter		Blind	with meter		Local meter	Output & Safety approvals
	Analog	Digital		Analog	Digital		
ESD	ESI	ESJ	RSQ	RST	RSZ	4 - 20 mA with HART®, intrinsically safe	
ESA	ESG	ES9	RSW	RSX	RS4	4 - 20 mA with HART®, explosion proof	
EZA	EZG	-	RZW	RZX	-	4 - 20 mA, explosion proof	



complete order code for EZ Modulelevel transmitter – non steam applications / high pressure

SELECTION DATA – steam applications (from 900 lbs to 2500 lbs)

A complete measuring system consists of:

- One order code for a complete standard EZ Modulelevel® transmitter.
Order code for modified models/adders or units with a digital meter: put an "X" in front of the closest matching order code and specify the modification/adders separately.
e.g: XE53-KL5A-ESD X = material certification EN 10204 / DIN 50049-3.1.B
- Options - see page 3

1. Order code for Standard EZ Modulelevel® transmitter – steam applications / high pressure

BASIC MODEL NUMBER

E 5 1	top mounted EZ Modulelevel	- Carbon steel construction
E 5 2	top mounted EZ Modulelevel	- Stainless steel construction
E 5 3	EZ Modulelevel with side/bottom cage	- Carbon steel construction
E 5 4	EZ Modulelevel with side/bottom cage	- Stainless steel construction
E 5 5	EZ Modulelevel with side/side cage	- Carbon steel construction
E 5 6	EZ Modulelevel with side/side cage	- Stainless steel construction

SPECIFIC GRAVITY AND PROCESS TEMPERATURE

integral 150° C	integral 200° C	integral 230° C	remote 260° C	mounting max. temp.
K	B	N	R	0.55 - 1.09 specific gravity

TANK CONNECTION (for DIN flanges consult factory)

a. For top mounted connection type (E51, E52) - head flange rating

RJ900 lb	RJ 1500 lb	RJ 2500 lb	RF: raised face - RJ: ring joint
H7	H8	H9	4" size
K7	K8	K9	6" size

b. For external cage models (E53, E54, E55, E56) - ANSI cage rating

RJ 900 lb	RJ 1500 lb	RJ 2500 lb	connection
L5	L7	L9	1 1/2" NPT
M5	M7	M9	1 1/2" socket weld
P7	P8	P9	1 1/2" ANSI flanges
L6	L8	L0	2" NPT
M6	M8	M0	2" socket weld
Q7	Q8	Q9	2" ANSI flanges

LEVEL RANGE (consult factory for longer level range)

356	813	1219	1524	mm
14	32	48	60	inches
A	B	C	D	code

TRANSMITTER – ELECTRONICS

INTEGRAL MOUNT ELECTRONICS						REMOTE ELECTRONICS			24 V DC amplifier head	
Max +150 °C (K only)			Max +230 °C (B or N)			Max +260 °C (R only)			Process Temperature (codes as per digit 4)	
Blind	with meter		Blind	with meter		Blind	with meter		Local meter	Output & Safety approvals
	Analog	Digital		Analog	Digital		Analog	Digital		
ESD	ESI	ESJ	ESH	ESK	ES8	RSQ	RST	RSZ	4 - 20 mA with HART®, intrinsically safe	
ESA	ESG	ES9	ESE	ESF	ES7	RSW	RSX	RS4	4 - 20 mA with HART®, explosion proof	
EZA	EZG	-	EZE	EZF	-	RZW	RZX	-	4 - 20 mA, explosion proof	



complete order code for EZ Modulelevel transmitter – steam applications / high pressure

OPERATING TEMPERATURES

The following charts lists combinations of process and ambient temperatures that should not be exceeded, with standard instruments

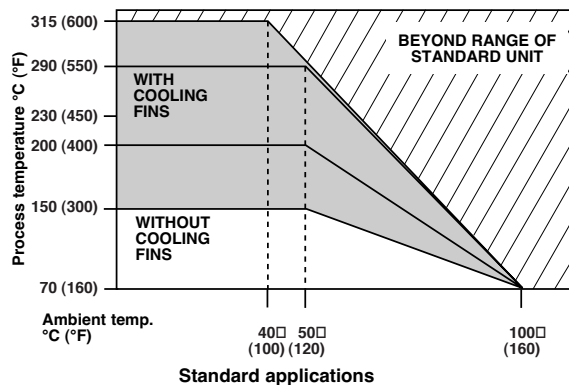
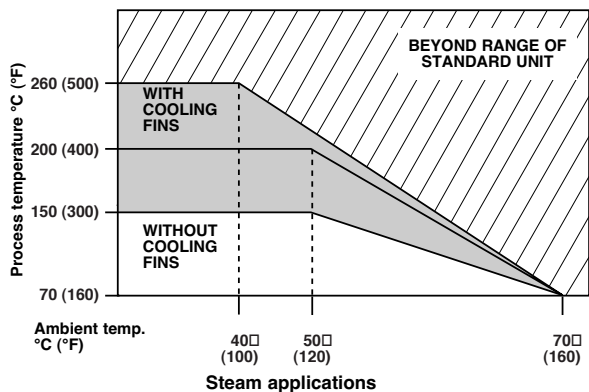

TEMPERATURE EXTENSIONS

Models E6x-A/B/C
max 200°C (400°F)

Models E6x-M/N/P
max 230°C (450°F)

Models E6x-D/E/F
max 290°C (550°F)

Models E6x-Q/R/T
max 315°C (600°F)

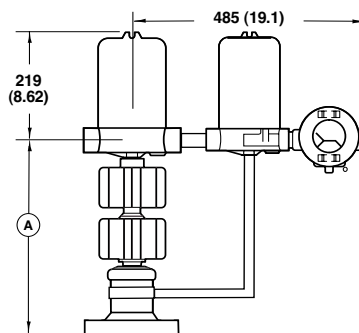
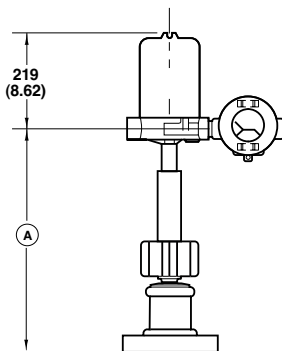
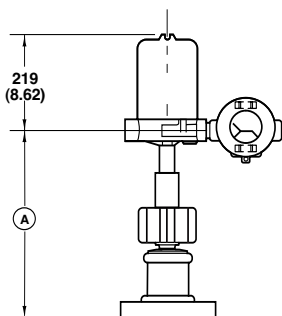
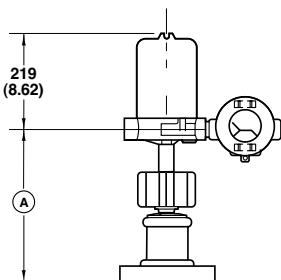

Models Spec. gravity	Dimensions ^A			
	E6x-A/B/C	E6x-M/N/P	E6x-D/E/F	E6x-Q/R/T
0.23 to 0.54	464 (18.27)	566 (22.28)	668 (26.30)	464 (18.27)
0.55 to 1.09	415	517	619	415
1.10 to 2.20	(16.34)	(20.35)	(24.37)	(16.34)

ELECTRICAL WIRING

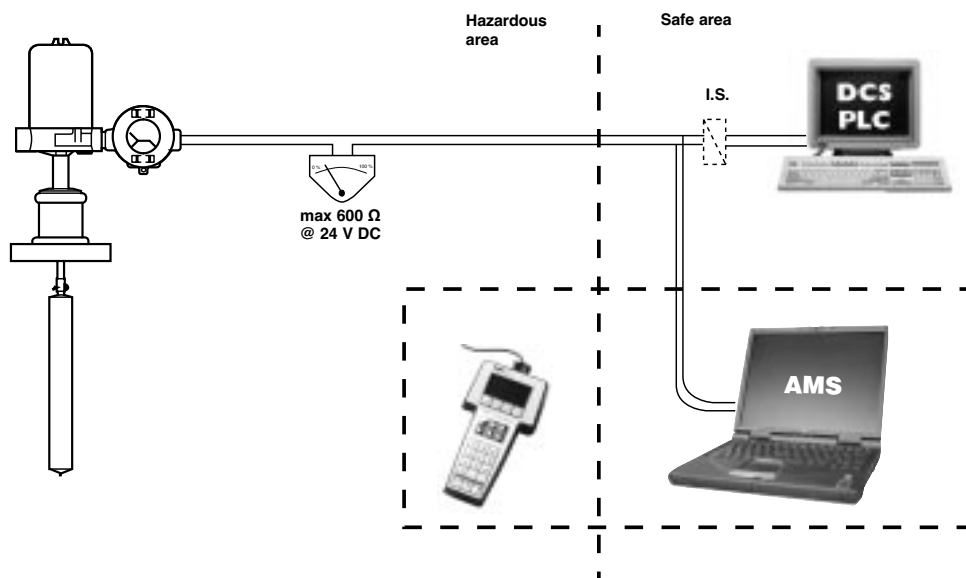

PHYSICAL/ELECTRICAL SPECIFICATIONS

Description		EZ Modulelevel with Hart®	EZ Modulelevel without Hart®
Power (at terminals)		ATEX intrinsically safe: 11 to 28,6 V DC (@ 94 mA) ATEX explosion proof / Non Ex: 12 to 36 V DC	
Signal output		4 – 20 mA (direct / reverse action) 3,8 to 20,5 mA usable (meets NAMUR NE 34) with Hart® (soft Rev. x.5) and AMS® supported	4 – 20 mA (direct / reverse action)
Span		356 mm up to 3048 mm (14" up to 120") (6000 mm (240") at request)	
Loop resistance		600 Ohm at 24 V DC Max 545 Ohm when used in combination with 22 mA error signal	600 Ohm at 24 V DC
Damping		0 to 60 s	none
Diagnostic alarm		3,6 mA or 22 mA or HOLD last value (3,6 mA is not valid if unit includes both digital display and HART®)	none
User interface		Zero/span and error LED's 3-button keypad and/or HART® / AMS®	External explosion proof potentiometers for 0 % and 100 %
Display		None (blind), or with local analog or digital meter	
Housing material		IP 66, epoxy coated cast iron or stainless steel	
Wetted materials	Spring	Inconel (other materials at request)	
	Displacer	316/316L SST (1.4401/1.4404) or 304 SST (1.4301)	
Cage materials		Carbon steel or 316/316L SST (1.4401/1.4404) (other materials at request)	
Approvals		ATEX II 1G EEx ia II C T6, intrinsically safe ATEX II 1/2G EEx d II C T6, explosion proof FM/CSA/SAA, explosion proof LRS, Lloyds Register of Shipment (marine applications) Other approvals are available, consult factory	
SIL (Safety Integrity Level)		Functional safety to SIL 1 / SIL 2 (redundant installation in accordance to IEC 61508. Full FMEDA report available.	
Electrical data		Ui = 28,6 V; li = 94 mA; Pi = 0,68 W	
Equivalent data		Ci = 5 nF; Li = 800 µH	
Net and gross weight		14 kg (head with meter)	

PERFORMANCE

Description	Specifications
Linearity	± 0,25 % of full span
Accuracy	0,5 %
Resolution	0,05 % of range ± 1 digit
Repeatability	0,25 % of full span
Response time	Less than 1s (electronics)
Sampling rate	15 times / s (digital meter: 1.33 / s)
Ambient temperature	-40 °C to 70 °C (-40 °F to 160 °F)
Process temperature	-30 °C to 315 °C / 260 °C for steam @ 50 °C ambient temp (-20 °F to 500 °F (600 °F for steam) @ 120 °F ambient temp) Max. temp. needs to be derated in case of higher ambient temperature. For lower process temperature – use Stainless steel constructions.
Process pressure	Max 355 bar (5150 psi) Flanged models are downrated to the design pressure of the selected flange.
Operating temp. effect	< 0,027 % / °C for -20 °C to 70 °C (0 °F to 160 °F)
Density range	Min 0,23 S.G. – Max 2,20 S.G.
Humidity	0-99 %, non condensing
Electromagnetic compatibility	Meets CE requirements (EN-50081-2, EN 50082-2)

DIMENSIONS in mm (inches) – E6X MODELS
 (For temperature extensions - see page 8)

E61/E62 – Top Mount, Integral Electronics
max 150°C (300°F)

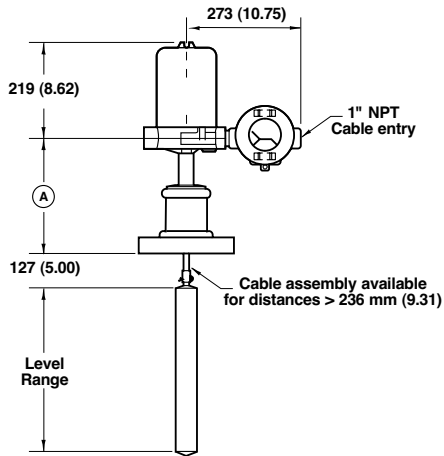

E65/E66 – Side-Side Connections,
Integral Electronics
max 150°C (300°F)

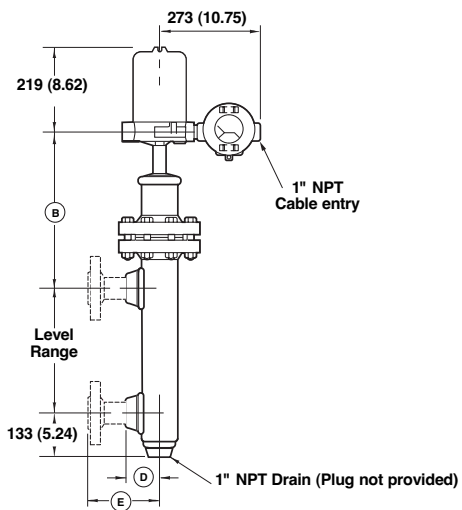

E63/E64 – Side-Bottom Connections,
max 150°C (300°F)

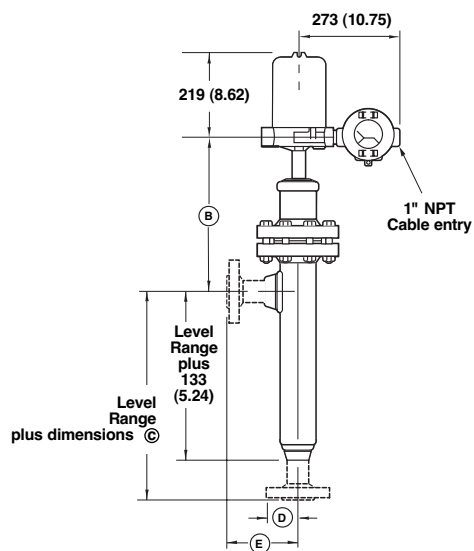

Range Spring Specific Gravity Rating	Dimensions	
	(A)	(B)
0.23 to 0.54	363 (14.29)	490 (19.29)
0.55 to 1.09	313 (12.32)	440 (17.32)
1.10 to 2.20		

Flange Size	Dimensions	
	(C)	(E)
1 1/2" - DN 40	268 (10.55)	180 (7.09)
2" - DN 50	273 (10.75)	185 (7.28)

Process connection	Dimensions
	(D)
1 1/2" NPT & S.W.	81(3.19)
2" NPT & S.W.	84 (3.31)

DIMENSIONS in mm (inches) – E5X MODELS
 (For temperature extensions - see page 8)

E51/E52 – Max 100 PN
 Top mount, integral electronics

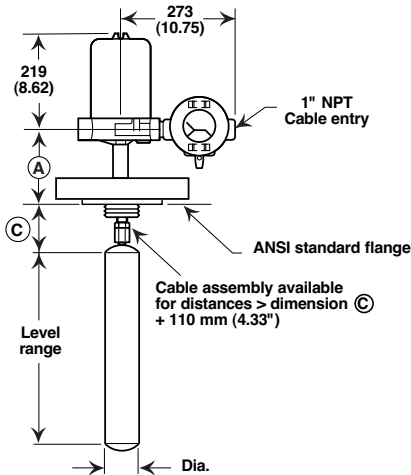

E51/E52 – Max 2500 lbs
 Top mount, integral electronics

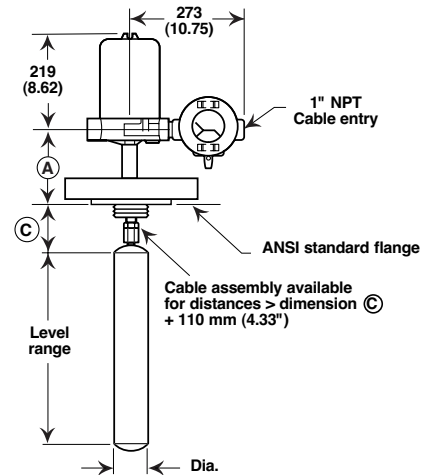

Connection		Range spring specific gravity rating			
		0.23 to 0.54		0.55 to 1.09 1.10 to 2.20	
Size	Rating	(A)	(C)	(A)	(C)
DN 80	PN 16	172 (6.77)	312 (12.28)	172 (6.77)	262 (10.31)
	PN 40	176 (6.93)	308 (12.13)	176 (6.93)	258 (10.16)
	PN 64	180 (7.09)	304 (11.97)	180 (7.09)	254 (10.00)
	PN 100	184 (7.24)	300 (11.81)	184 (7.24)	250 (9.84)
DN 100	PN 16	172 (6.77)	312 (12.28)	172 (6.77)	262 (10.31)
	PN 40	176 (6.93)	308 (12.13)	176 (6.93)	258 (10.16)
	PN 64	182 (7.17)	302 (11.89)	182 (7.17)	252 (9.92)
	PN 100	188 (7.40)	296 (11.65)	188 (7.40)	246 (9.69)
DN 150	PN 16	174 (6.85)	310 (12.20)	174 (6.85)	260 (10.24)
	PN 40	180 (7.09)	304 (11.97)	180 (7.09)	254 (10.00)
	PN 64	188 (7.40)	296 (11.65)	188 (7.40)	246 (9.69)
	PN 100	196 (7.72)	288 (11.34)	196 (7.72)	238 (9.37)

Outlet Size		Dimensions	
Size	Rating	(A)	(C)
4"	RJ 900 lbs	205 (8.07)	300 (11.81)
	RJ 1500 lbs	215 (8.46)	290 (11.42)
	RJ 2500 lbs	240 (9.45)	310 (12.21)
6"	RJ 900 lbs	215 (8.46)	290 (11.42)
	RJ 1500 lbs	245 (9.65)	305 (12.00)
	RJ 2500 lbs	275 (10.83)	290 (11.42)

E55/E56 – Side-Side, Integral Electronics

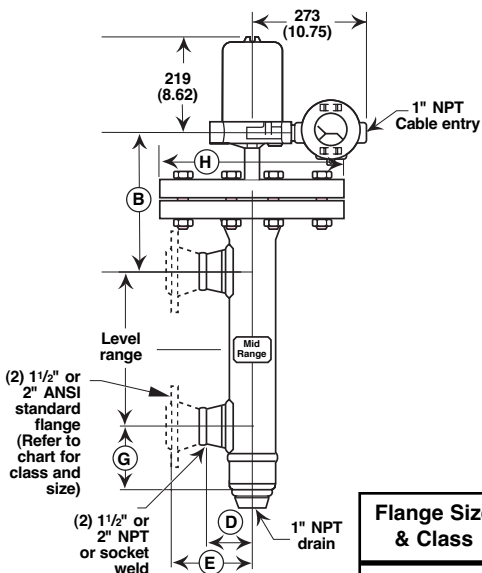

Flange Size & Class	Dimensions (consult factory for DIN flanges)				
	(B)	(E)	(F)	(G)	(H)
1 1/2" – 900 lb.	505 (19.88)	184 (7.25)	214 (8.43)	87 (3.44)	292 (11.50)
2" – 900 lb.		208 (8.18)	238 (9.38)		
1 1/2" – 1500 lb.	505 (19.88)	201 (7.93)	232 (9.38)	87 (3.44)	311 (12.25)
2" – 1500 lb.		225 (8.87)	257 (10.13)		
1 1/2" – 2500 lb.	550 (21.65)	230 (9.06)	267 (10.25)	87 (3.44)	356 (14.00)
2" – 2500 lb.		251 (9.87)	283 (11.13)		

E53/E54 – Side-Bottom, Integral Electronics

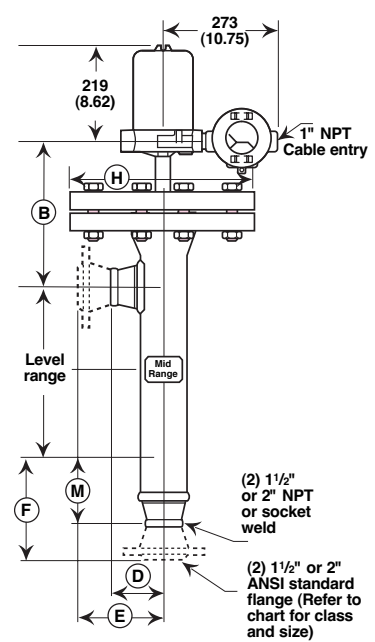

Outlet Size	Dimensions	
	(D)	(M)
1 1/2" NPT or Socket Weld	102 (4.00)	87 (3.44)
2" NPT or Socket Weld	111 (4.38)	89 (3.50)



QUALITY ASSURANCE - ISO 9001:2000

THE QUALITY ASSURANCE SYSTEM IN PLACE AT MAGNETROL GUARANTEES THE HIGHEST LEVEL OF QUALITY DURING THE DESIGN, THE CONSTRUCTION AND THE SERVICE OF CONTROLS. OUR QUALITY ASSURANCE SYSTEM IS APPROVED AND CERTIFIED TO **ISO 9001:2000** AND OUR TOTAL COMPANY IS COMMITTED TO PROVIDING FULL CUSTOMER SATISFACTION BOTH IN QUALITY PRODUCTS AND QUALITY SERVICE.

PRODUCT WARRANTY

ALL MAGNETROL MECHANICAL LEVEL CONTROLS ARE WARRANTED FREE OF DEFECTS IN MATERIALS AND WORKMANSHIP FOR FIVE FULL YEARS FROM THE DATE OF ORIGINAL FACTORY SHIPMENT.

IF RETURNED WITHIN THE WARRANTY PERIOD; AND, UPON FACTORY INSPECTION OF THE CONTROL, THE CAUSE OF THE CLAIM IS DETERMINED TO BE COVERED UNDER THE WARRANTY; THEN, MAGNETROL INTERNATIONAL WILL REPAIR OR REPLACE THE CONTROL AT NO COST TO THE PURCHASER (OR OWNER) OTHER THAN TRANSPORTATION.

MAGNETROL SHALL NOT BE LIABLE FOR MISAPPLICATION, LABOR CLAIMS, DIRECT OR CONSEQUENTIAL DAMAGE OR EXPENSE ARISING FROM THE INSTALLATION OR USE OF THE EQUIPMENT. THERE ARE NO OTHER WARRANTIES EXPRESSED OR IMPLIED, EXCEPT, SPECIAL WRITTEN WARRANTIES COVERING SOME MAGNETROL PRODUCTS.



BULLETIN N°: BE 48-106.5
EFFECTIVE: SEPTEMBER 2004
SUPERSEDES: August 2004

UNDER RESERVE OF MODIFICATIONS

BENELUX	Heikensstraat 6, 9240 Zele, België Tel. +32 (0)52.45.11.11 • Fax. +32 (0)52.45.09.93 • E-Mail: info@magnetrol.be
DEUTSCHLAND	Alte Ziegelei 2-4, D-51491 Overath Tel. 02204 / 9536-0 • Fax. 02204 / 9536-53 • E-Mail: vertrieb@magnetrol.de
FRANCE	40 - 42, rue Gabriel Péri, 95130 Le Plessis Bouchard Tél. 01.34.44.26.10 • Fax. 01.34.44.26.06 • E-Mail: magnetrolfrance@magnetrol.fr
ITALIA	Via Arese 12, I-20159 Milano Tel. (02) 607.22.98 (R.A.) • Fax. (02) 668.66.52 • E-Mail: mit.gen@magnetrol.it
UNITED KINGDOM	Unit 1 Regent Business Centre, Jubilee Road Burgess Hill West Sussex RH 15 9TL Tel. (01444) 871313 • Fax (01444) 871317 • E-Mail: sales@magnetrol.co.uk
INDIA	E-22, Anand Niketan, New Delhi - 110 021 Tel. 91 (11) 51661840 • Fax 91 (11) 51661843 • E-Mail: magnetrolindia@vsnl.com

www.magnetrol.com

OUR NEAREST REPRESENTATIVE