

# LHL - LHI - LFS mA

## LHL LIMITROL® - front description

### RESET indicator

- flashes during a shutdown condition if the shutdown condition has not been acknowledged;
- lights during a shutdown condition if the shutdown condition has been acknowledged;
- off when the shutdown condition is not present.

### ALM indication

- flashes when the instrument is in alarm condition;
- lights when the instrument is in alarm condition but the alarm condition has been acknowledged;
- off when no alarm condition is present.



### Upper display

Shows the measured value or the last shutdown duration (in hours and minutes) or either the maximum or minimum measured value detected during the last shutdown condition. During parameter setting procedures, it shows the value of the selected parameter.

### REM indicator

Flashes when the instrument is under host computer control by serial communication interface.

### Lower display

It shows the code of the displayed variable (measure, time or peak) or the code of the selected parameter.

### Keyboard

**RESET** allows acknowledgement of the shutdown condition. During parameter modification it allows you to go back to the previous parameter without memorizing the actual parameter value.

▼ During normal operation it allows you to select the desired displayed information. During parameter modification it allows you to decrease the value of the selected parameter.

▲ During normal operation it allows you to select the desired displayed information. During parameter modification it allows you to increase the value of the selected parameter.

**FUNC** During normal operation it allows you to start the parameter modification procedure. During parameter modification it allows you to memorize the new parameter value and go to the next parameter.

## LHI - front description

### AL1 and AL2 indicators

- flashes when the instrument is in alarm condition;
- lights when the instrument is in alarm condition but the alarm condition has been acknowledged;
- Off when no alarm condition is present.



### Upper display

Shows the measured value. During parameter setting procedures, it shows the value of the selected parameter.

### REM indicator

Flashes when the instrument is under host computer control by serial communication interface.

### Lower display

It shows the engineering unit of the measured variable or the code of the selected parameter.

### Keyboard

**RESET** allows you to reset manually an alarm condition. During parameter modification it allows you to go back to the previous parameter without memorizing the current parameter value.

▼ During normal operation it allows you to select the desired displayed information (measure or peaks). During parameter modification it allows you to decrease the value of the selected parameter.

▲ During normal operation it allows you to select the desired displayed information (measure or peaks). During parameter modification it allows you to increase the value of the selected parameter.

**FUNC** During normal operation it allows you to start the parameter modification procedure. During parameter modification it allows you to memorize the new parameter value and go to the next parameter.

## LFS mA - indicator-transmitter

The **LFS mA**, suitable for industrial application, is an instrument extremely flexible which allows a quick and easy working independent of the PC or any other supervisory system.

The display and the front keyboard (standard supplied) allow to avoid the typical problem due to the use of removable remote keyboard programmer.

However, the instrument, is completely configurable through serial link (option).



The signal retransmission is programmable on the entire range of measure or on part of it.

The input signal is optoisolated with respect to the mA linear output signal.

Contemporarily with the analog retransmission it is possible to have the isolated RS 485 communication (option).

Two alarms with relay output are available. The thresholds may be independent or interacting one each other (the second alarm may be set as deviation or band of the first one).

A logic input contact allows to select the alarm threshold between two values which may be stored into the instrument.



Safety limiters have been used for years, in processes where exceeding a specific value (temperature, pressure and so on) can be dangerous to the operator or process equipment.

The LHL Limitrol® and LHI indicator, developed in cooperation with USA members of SIEBE group, are specific, complete and compact instruments, designed in order to meet these needs.

This allows to remove the external relay logic normally used to get the necessary alarm reset sequence.

#### **These instruments:**

- Meet or exceed Factory Mutual (FM) Approval Standard Temperature Limit Switches Class 3545 (LHL Limitrol® only);
- are easy to install and put in service;
- have universal input (TC, RTD, mV DC, V DC, mA DC);
- facilitate 3 types of passcode security;
- offer time-in-reset display (LHL Limitrol® only);
- store peak measure for operator retrieval and information;
- eliminate confusion with Manual/Automatic reset option at power-up;
- are rated IP 65 and NEMA 4X to allow wash-down in food plants;
- simplify and standardize all plant instrumentation;
- are in accordance with CE regulations;
- offer a new level of security and reliability for the entire plant.

## **LIMITROL® - the safety limiter**

The function of the instrument is to provide a contact actuation which can be used to automatically shutdown a process when the measured value exceeds a pre-programmed value.

#### **Rearming (reset) function**

After a shutdown, when it is desired to rearm (reset) the safety limiter (and restart the process), the following must occur:

- 1) the condition which generated the shutdown, no longer exists;
- 2) the shutdown condition has been acknowledged by manual intervention.

#### **Acknowledgement of the shutdown condition**

Is a physical action taken by the operator (push-button pressure, contact closure or a command via serial link).

This action may be made only when the abnormal condition which generated the shutdown status, no longer exists.

# LHL - LHI

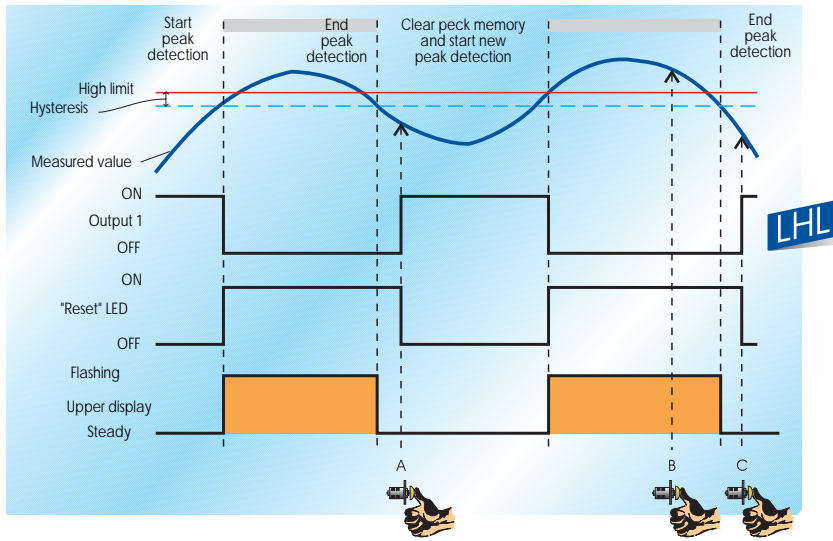

Figure 1

This example describes the LHL Limitrol® behaviours in relation to the **acknowledgement of the shutdown condition** (points A, B and C) when it is programmed as a high limiter.

This example assumes the following rearming (reset) mode which is selectable during instrument configuration.

- Acknowledgements rearm (reset) the limiter (and restart the process) only if the condition which generated the shutdown status no longer exists (points A and C),
- Acknowledgements do not generate any effect if the condition which generated the shutdown status still exists (point B).

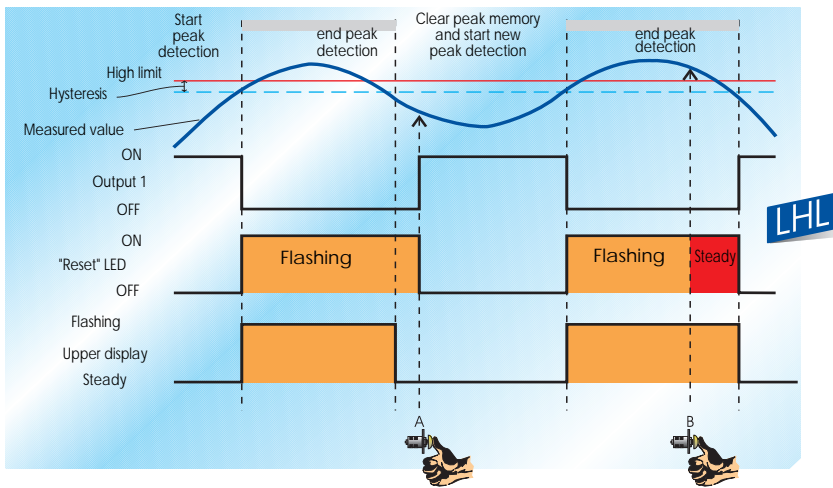

Figure 2

This example also describes the LHL Limitrol® behaviours in relation to the **acknowledgement of the shutdown condition** (points A and B) when it is programmed as a high limiter; but, in this case, the second rearming (reset) mode, described below, has been selected.

- Acknowledgements rearm (reset) the limiter (and restart the process) only if the condition which generated the shutdown status no longer exists (points A),
- acknowledgements enable the automatic rearmament (reset) of the limiter if the condition which generated the shutdown status still exists (point B). (The instrument rearms (reset) automatically when the condition which generated the shutdown status no longer exists).

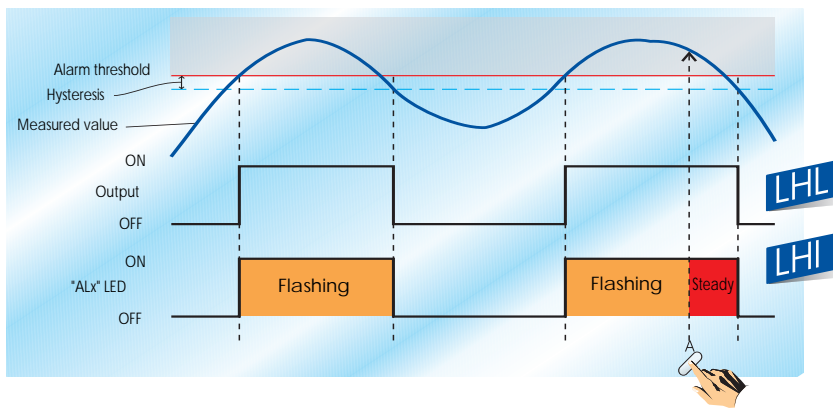

Figure 3

High alarm with automatic reset.

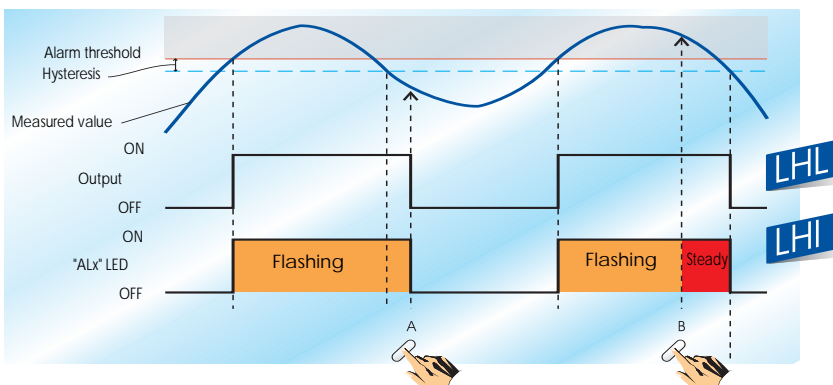

Figure 4

High alarm with manual reset.



# LHL Limitrol<sup>®</sup> safety limiter

## OUTPUTS

These instruments are equipped with 2 independent outputs.  
The first one is used as a limiter output while the second operates as an alarm output.

### Output 1

**Type:** relay  
**Contact:** SPDT  
**Contact rating:** 3 A at 250 V AC on resistive load.  
**Action:** fail safe (relay energized in no shutdown status).  
**Output status indication:** one red LED marked RESET:  
- flashes during a shutdown condition if the shutdown condition has not been acknowledged;  
- lights during a shutdown condition if the shutdown condition has been acknowledged;  
- Off when the shutdown condition is not present.

### Output 2 (optional)

**Type:** relay  
**Contact:** SPST (normally open).  
**Contact rating:** 2 A at 250 V AC on resistive load.  
**Action:** programmable  
- direct (relay energized in alarm condition);  
- reverse (relay deenergized in alarm condition).  
**Output status indication:** one red LED marked ALM:  
- flashes when the instrument is in the alarm condition;  
- lights when the instrument is in the alarm condition but the alarm condition has been acknowledged;  
- Off when no alarm condition is present.

## SAFETY LIMITER

### Function

- high limiter  
- low limiter  
- high and low limiter

**Set point (threshold) of the limiter:** programmable, in engineering units, within the readout range.  
**Hysteresis:** programmable from 0.1% to 10.0% of the readout span.

### Rearming (reset) of the limiter

After a shutdown, when it is desired to rearm (reset) the safety limiter (and restart the process), it is necessary that:  
1) the condition which generated the shutdown, no longer exists.  
2) the operator has acknowledged the shutdown condition.

### Acknowledgement of the shutdown condition

It may be made by a front push-button, external contact or serial link.  
The instrument will operate as described in figures 1 or 2 in accordance with the specific configuration.

## ALARM

### Alarm function

is programmable as: a process alarm, band alarm or deviation alarm.

**Note:** 1) the band and deviation alarms are referred to the limiter threshold (see figures 6 and 7) so that if the threshold has been modified, the alarm will also change.  
2) When the instrument is programmed as a high/low limiter, the band and deviation alarms are not available.

### Alarm reset

- Automatic (see figure 3)  
- Manual (see figure 4)  
- "Silence" function

**Note:** the "Silence" function is a typical function of the alarm annunciators (see ISA alarm annunciator operational sequence) and it is usually applied to audible alarm indications (horns). For other details see figure 5.

### Process alarm

**Operative mode:** programmable as a high or low alarm.  
**Alarm threshold:** programmable in engineering units within the readout range.  
**Hysteresis:** from 0.1% to 10.0% of the readout span.

### Band alarm

**Operative mode:** programmable as inside band or outside band.  
**Alarm threshold:** programmable from 0 to 500 units.  
**Hysteresis:** from 0.1% to 10.0% of the readout span.

### Deviation alarm

**Operative mode:** Deviation high or deviation low.  
**Threshold:** programmable from -500 to +500 units.  
**Hysteresis:** from 0.1% to 10.0% of the readout span.

## SPECIAL FUNCTIONS

### Stand by (masking) of the alarm

The alarm can be programmed as a masked or standard alarm. Alarm masking puts the alarms in the stand by condition (mask) during instrument power up or masks a deviation or band alarm if the alarm condition is a result of a set point change. In both situations the instrument maintains the alarm masking for the duration of the alarm condition.

### Logic input

These instruments are equipped with a logic input used to acknowledge a shutdown condition by an external contact.

### Maximum and/or minimum data hold

During a shutdown condition, the instrument memorizes the maximum and/or the minimum measured value (see fig. 1).  
If the instrument is programmed as low limiter, it will memorize the minimum measured value.  
If the instrument is programmed as high limiter, it will memorize the maximum measured value.  
If the instrument is programmed as high/low limiter, it will memorize the maximum and the minimum measured values.

### Power supply failure indication

These instruments are able to signal if a power failure occurs during normal instrument operation.  
Some parameters allows the selection of instrument behaviour at power up.

# LHI indicator

---

## OUTPUTS

### Output 1

<b>Type:</b>	relay
<b>Contact:</b>	SPDT
<b>Contact rating:</b>	3 A at 250 V AC on resistive load.
<b>Action:</b>	programmable - direct (relay energized in alarm condition); - reverse (relay deenergized in alarm condition).
<b>Output status indication:</b>	one red LED marked AL1: - flashes when the instrument is in alarm condition; - lights when the instrument is in alarm condition but the alarm condition has been acknowledged; - Off when no alarm condition is present.

---

### Output 2 (optional)

<b>Type:</b>	relay
<b>Contact:</b>	SPST (normally open).
<b>Contact rating:</b>	2 A at 250 V AC on resistive load.
<b>Action:</b>	programmable - direct (relay energized in alarm condition); - reverse (relay deenergized in alarm condition).
<b>Output status indication:</b>	one red LED marked AL2: - flashes when the instrument is in alarm condition; - lights when the instrument is in alarm condition but the alarm condition has been acknowledged; - Off when no alarm condition is present.

---

## ALARMS

<b>Type:</b>	Process alarm.
<b>Operative mode:</b>	programmable as high or low alarm.
<b>Alarm threshold:</b>	programmable in engineering units within the readout range.
<b>Hysteresis:</b>	from 0.1 % to 10.0% of the readout span.

---

### Alarm reset

- Automatic (see figure 3)
- manual (see figure 4)
- "Silence" function

**Note:** the "Silence" function is a typical function of the alarm annunciators (see ISA alarm annunciator operational sequence) and it is usually applied to audible alarm indications (horns).  
For other details see figure 5.

---

### Stand by (masking) of the alarm

The alarm can be programmed as a masked or standard alarm. Alarm masking puts the alarms in the stand by condition (mask) during instrument power up. The instrument maintains the alarm masking for the duration of the alarm condition.

---

## SPECIAL FUNCTIONS

### Logic input

These instruments are equipped with a logic input used to manually reset the alarms.

---

### Maximum and/or minimum data hold

The LHI is able to memorize the maximum and the minimum measured value. This function is automatically enabled at instrument power up and it is always active. By front push-button or serial link it is possible to display the memorized values and/or to delete the old values and start a new memorization period.

## GENERAL SPECIFICATIONS

<b>Case:</b>	self-extinguishing material according to UL 746C standard.
<b>Front protection:</b>	- designed and tested for IP 65 (*) and NEMA 4X (*) for indoor locations (when panel gasket is installed). - IP 20 for rear of board version. - (*) Test were performed in accordance with IEC 529, CEI 70-1 and NEMA 250-1991 STD.
<b>Installation:</b>	- panel mounting version by means of tie rods. - Rear of board version on wall or omega DIN rail.
<b>Rear terminal board:</b>	with screw terminals, connection diagram and safety rear cover.
<b>Dimensions:</b>	48 x 48 mm (according to DIN 43700); depth - 122 mm for models with RS-485. - 105 mm for models without RS-485
<b>Weight:</b>	250 g. max. (1/2 lb.).
<b>Power supply:</b>	(switching mode) from 100 to 240 V AC. 50/60 Hz (+10 % to -15 % of the nominal value) or 24 V DC/AC (+10 % of the nominal value). 5 W.
<b>Power consumption:</b>	5 W.
<b>Insulation resistance:</b>	>100 M $\Omega$ according to IEC 1010-1.
<b>Isolation voltage:</b>	1500 V r.m.s. according to IEC 1010-1.
<b>Common mode rejection ratio:</b>	120 dB @ 50/60 Hz.
<b>Normal mode rejection ratio:</b>	60 dB @ 50/60 Hz.
<b>Electromagnetic compatibility and safety requirements:</b>	This instrument is marked CE. Therefore, it is conforming to council directives 89/336/EEC (reference harmonized standard EN-50081-2 and EN-50082-2) and to council directives 73/23/EEC and 93/68/EEC (reference harmonized standard EN 61010-1).
<b>Installation category:</b>	II.
<b>D/A conversion:</b>	dual slope integration.
<b>Sampling time:</b>	- for linear inputs = 250 ms. - for TC or RTD inputs = 500 ms.
<b>Accuracy:</b>	+ 0.2% f.s.v. @ 25 °C and nominal power supply voltage.
<b>Operative temperature:</b>	from 0 to +50 °C.
<b>Storage temperature:</b>	from -20 to +70 °C.
<b>Humidity:</b>	from 20% to 85% RH not condensing.

## MEASURING INPUTS

All inputs are factory calibrated and selectable by front keyboard.

### Thermocouples

<b>Type:</b>	B, C, D, E, G, L, J, K, N, Platinel II, R, S, T and U keyboard programmable.
<b>Engineering unit:</b>	°C and °F keyboard programmable.
<b>Burn out:</b>	Detection of the open input circuit (wires or sensor) with underrange or overrange selectable indication.
<b>Cold junction:</b>	automatic compensation for an ambient temperature between 0 and 50 °C.
<b>Cold junction compensation error:</b>	0.1 °C/°C.
<b>Input impedance:</b>	> 100 k $\Omega$ .
<b>Calibration:</b>	according to IEC 584-1.

STANDARD RANGES TABLE

TC type	°C	Range	°F
B	0 / 1820		+32 / 3300
C (W5)	0 / 2300		0 / 4170
D (W3)	0 / 2300		0 / 4170
E	-100 / 800		-150 / 1470
G (W)	0 / 2300		0 / 4170
L	-100 / 900		-150 / 1650
J	-100 / 1000		-150 / 1830
K	-100 / 1370		-150 / 2500
N	-100 / 1400		-150 / 2550
Platinel II	-100 / 1400		-150 / 2550
R	-50 / 1760		-60 / 3200
S	-50 / 1760		-60 / 3200
T	-200 / 400		-330 / 750
U	-200 / 600		-330 / 1110



**RTD input**

**RTD type:** Pt 100 3 wire connection.  
**Calibration:** according to DIN 43760  
**Line resistance:** Max 20 Ω/wire with no measurable error.  
**Engineering unit:** °C and °F keyboard programmable.  
**Burn out:** Detection of the sensor open circuit and of one or more wires open circuit.  
 The instrument shows the short circuit indication when the resistance of the sensor is lower than 15 Ω.  
**Standard ranges:** - from -200 to 850 °C  
 - from -330 to 1560 °F

**Linear inputs (mA and V)**

**Type:** see table  
**Read-out:** keyboard programmable from -1999 to 4000.  
**Decimal point:** programmable in any position.

STANDARD RANGES TABLE

Input		Impedance	
0 - 20	mA	5	Ω
4 - 20	mA	5	Ω
0 - 60	mV	> 1	MΩ
12 - 60	mV	> 1	MΩ
0 - 5	V	> 400	kΩ
1 - 5	V	> 400	kΩ
0 - 10	V	> 400	kΩ
2 - 10	V	> 400	kΩ

**SERIAL INTERFACE**  
 (optional)

**Types:** RS-485.  
**Protocol type:** MODBUS, JBUS.  
**Baud rate:** programmable from 600 to 19200 BAUD.  
**Byte format:** 8 bit.  
**Parity:** even, odd or none programmable.  
**Stop bit:** one.  
**Address:** from 1 to 255.  
**Output voltage levels:** according to EIA standard.



## GENERAL SPECIFICATIONS

<b>Case:</b>	self-extinguishing material according to UL 746C standard.
<b>Self-extinguishing degree:</b>	V0 according to UL-94.
<b>Front protection:</b>	- designed and tested for IP 65 (*) and NEMA 4X (*) for indoor locations (when panel gasket is installed). - IP 20 for rear of board version. - (*) Test were performed in accordance with IEC 529, CEI 70-1 and NEMA 250-1991 STD.
<b>Installation:</b>	- panel mounting version by means of tie rods. - Rear of board version on wall or omega DIN rail.
<b>Rear terminal board:</b>	with screw terminals, connection diagram and safety rear cover.
<b>Dimensions:</b>	48 x 48 mm (according to DIN 43700); depth 122 mm.
<b>Weight:</b>	250 g. max. (1 lb.).
<b>Power supply:</b>	(switching mode) from 100 to 240 V A.C. 50/60 Hz (+10% to -15% of the nominal value) or 24 V AC/DC ( $\pm 10\%$ of the nominal value).
<b>Power consumption:</b>	6 W.
<b>Insulation resistance:</b>	> 100 M $\Omega$ according to IEC 1010-1.
<b>Isolation voltage:</b>	1500 V r.m.s. according to IEC 1010-1.
<b>Common mode rejection ratio:</b>	120 dB @ 50/60 Hz.
<b>Normal mode rejection ratio:</b>	60 dB @ 50/60 Hz.
<b>Electromagnetic compatibility and safety requirements:</b>	This instrument is marked CE. Therefore, it is conformed to council directives 89/336/EEC (reference harmonized standard EN-50081-2 and EN-50082-2) and to council directives 73/23/EEC and 93/68/EEC (reference hamonized standard EN 61010-1).
<b>Installations category:</b>	II.
<b>D/A conversion:</b>	dual slope integration.
<b>Sampling time:</b>	- for linear inputs = 250 ms. - for TC or RTD inputs = 500 ms.
<b>Accuracy:</b>	$\pm 0.2\%$ f.s.v. @ 25 °C and nominal power supply voltage.
<b>Operative temperature:</b>	from 0 to +50 °C.
<b>Storage temperature:</b>	from -20 to +70 °C.
<b>Humidity:</b>	from 20% to 85% RH not condensing.
<b>Protections:</b>	1) WATCH DOG for automatic reset. 2) DIP SWITCHES for configuration and calibration parameters.

## MEASURING INPUTS

All the inputs are factory calibrated and selectable by front keyboard

### Thermocouples

<b>Type:</b>	J, K, L, R, S, N, T are keyboard programmable.
<b>Engineering unit:</b>	°C and °F keyboard programmable.
<b>Burn out:</b>	detection of input opening (wires or sensor) with underrange or overrange selectable.
<b>Cold junction:</b>	automatic compensation for an ambient temperature between 0 and 50 °C.
<b>Cold junction compensation error:</b>	0.1 °C/°C.
<b>Input impedance:</b>	> 1 M $\Omega$ .
<b>Calibration:</b>	according to IEC 584-1.

STANDARD RANGES TABLE

TC type	°C	Range	°F
L	0 / 400,0	0 / 1650	0 / 1650
L	0 / 900		
J	-100 / 400,0	-150 / 1830	-150 / 1830
J	-100 / 1000		
K	-100,0 / 400,0	-150 / 2190	-150 / 2190
K	-100 / 1200		
N	-100 / 1400	-150 / 2550	-150 / 2550
R	0 / 1760	0 / 3200	0 / 3200
S	0 / 1760	0 / 3200	0 / 3200
T	-199,9 / 400	-330 / 750	-330 / 750

**NOTE:** For TC inputs it is possible to select a measuring range, within the standard input range, with a minimum span of 300 °C or 600 °F. In this way it is possible to increase the sensibility of the control parameters.



## RTD input

**RTD type:** Pt 100 3 wires connection.  
**Calibration:** according to DIN 43760.  
**Line resistance:** max 20  $\Omega$ /wire with no appreciable error.  
**Engineering unit:** °C and °F keyboard programmable.  
**Burn out:** Detection of sensor opening and of one or more wires opening.  
 Detection of sensor short circuit.

### STANDARD RANGE TABLE

°C	°F
-199.9/ 400,0	-199.9/ 400,0
-200 / 800	-330 / 1470

**NOTE:** For RTD inputs it is possible to select a measuring range, within the standard input range, with a minimum span of 100 °C or 200 °F.  
 In this way it is possible to increase the sensibility of the control parameters.

## Linear inputs (mA and V)

**Type:** see table.  
**Read-out:** keyboard programmable from -1999 to 4000.  
**Decimal point:** programmable in any position.

### STANDARD RANGE TABLE

Input	Impedance
0 - 20 mA	> 5 $\Omega$
4 - 20 mA	> 5 $\Omega$
0 - 60 mV	> 1 M $\Omega$
12 - 60 mV	> 1 M $\Omega$
0 - 5 V	> 200 k $\Omega$
1 - 5 V	> 200 k $\Omega$
0 - 10 V	> 400 k $\Omega$
2 - 10 V	> 400 k $\Omega$

## OUTPUTS

### Output 1

**Type:** isolated 0-20 mA or 4-20 mA.  
**Function:** retransmission of the measured value.  
**Scaling:** programmable from -1999 to 9999.  
**Maximum load:** 500  $\Omega$ .  
**Resolution:** 0.05%.  
**Digital filter:** it is possible to apply a first order digital filter on the output retransmission, with the same time constant chosen for the read-out.  
**Output status indication:** the OUT 1 indicator flashes with a duty cycle proportional to the output level.

### Output 2

**Type:** relay SPST contact (NO or NC selectable by jumper).  
**Contact rating:** 2A at 250V AC on resistive load.  
**Function:** alarm 1 output (main) programmable as minimum or maximum process alarm.  
**Action:** direct (relay energized in alarm condition) or reverse (relay deenergized in alarm condition)

### Output 3

**Type:** relay SPST contact.  
**Contact rating:** 2A at 250V AC on resistive load.  
**Function:** alarm 2 output programmable as process alarm or as deviation threshold or band threshold with respect to the main alarm.  
**Action:** direct (relay energized in alarm condition) or reverse (relay deenergized in alarm condition)

## SERIAL INTERFACE

(optional)

**Type:** RS-485.  
**Protocol type:** MODBUS, JBUS, ERO polling/selecting.  
**Baud rate:** keyboard programmable from 600 to 19200 BAUD.  
**Byte format:** 7 or 8 bit programmable.  
**Parity:** even, odd or none programmable.  
**Stop bit:** one.  
**Address:** - from 1 to 95 for ERO protocol  
 - from 1 to 255 for all the other protocols  
**Output voltage levels:** according to EIA standard.



## HOW TO ORDER LHL - LHI

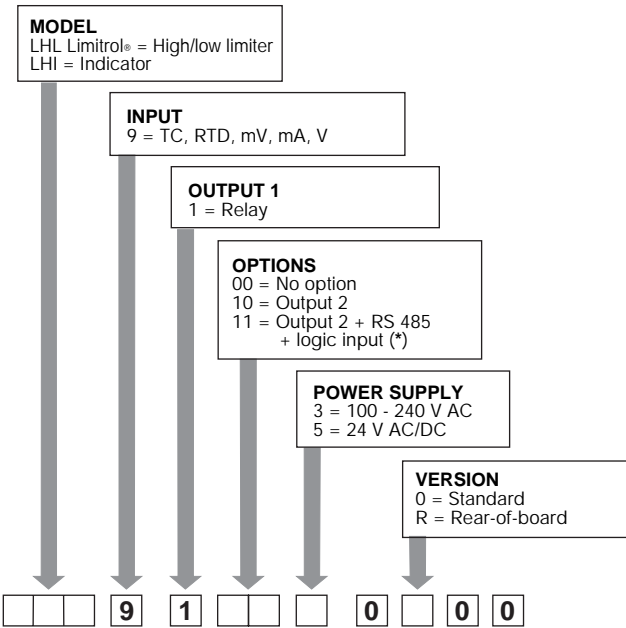

(\*) This option requires the long case format (depth 122 mm) and it uses the rear terminal block shown in **figure 9**. All the other models use the short case format (depth 105 mm) and they use the rear terminal block shown in **figure 10**.

Figure 9  
REAR TERMINAL BLOCK with RS-485

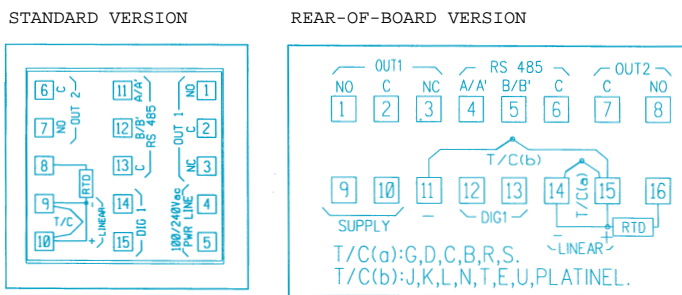
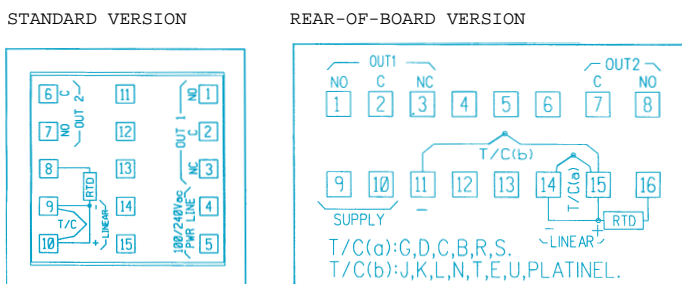
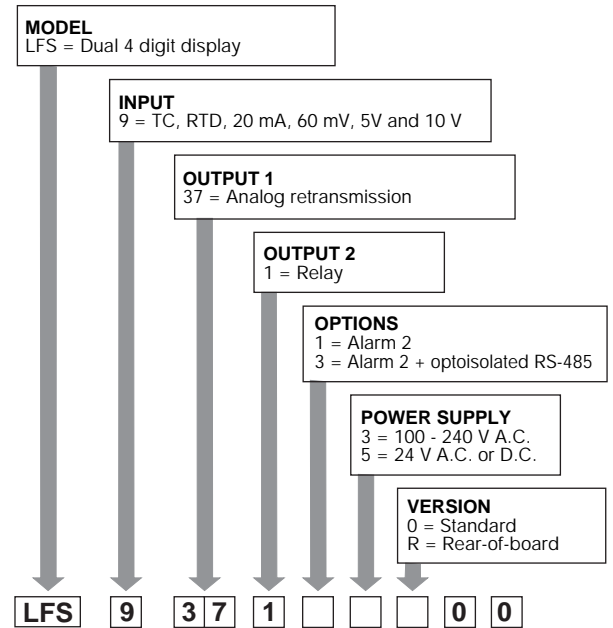

Figure 10  
REAR TERMINAL BLOCK without RS-485



## HOW TO ORDER LFS mA



REAR TERMINAL BLOCK LFS mA

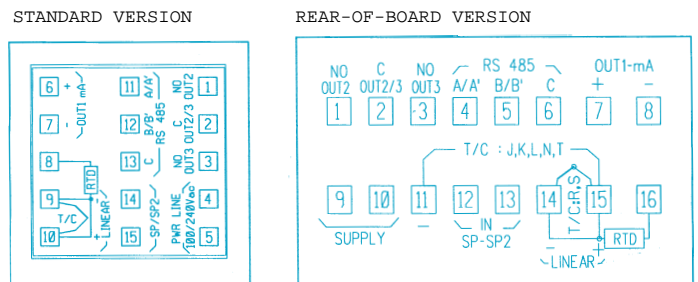

# LHL - LHI - LFS mA



## REAR OF BOARD VERSION

The range of these products encompasses also the rear of board version for the omega DIN rail mounting in accordance with EN 50022 (35 x 7.5 mm or 35 x 15 mm).

The rear of board version allows to:

- simplify the installation,
- reduce the panel space,
- reduce the wiring cost,
- protect the instrument from possible tampering of the settings.

Also these products guarantee the same reliability, versatility and ease of use which are standard characteristics of ERO Electronic products.

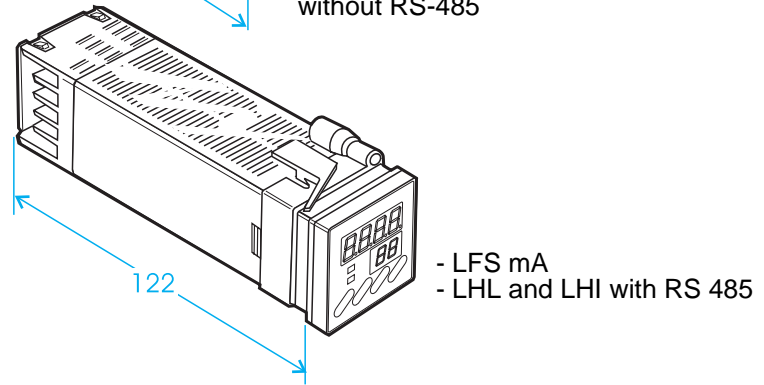
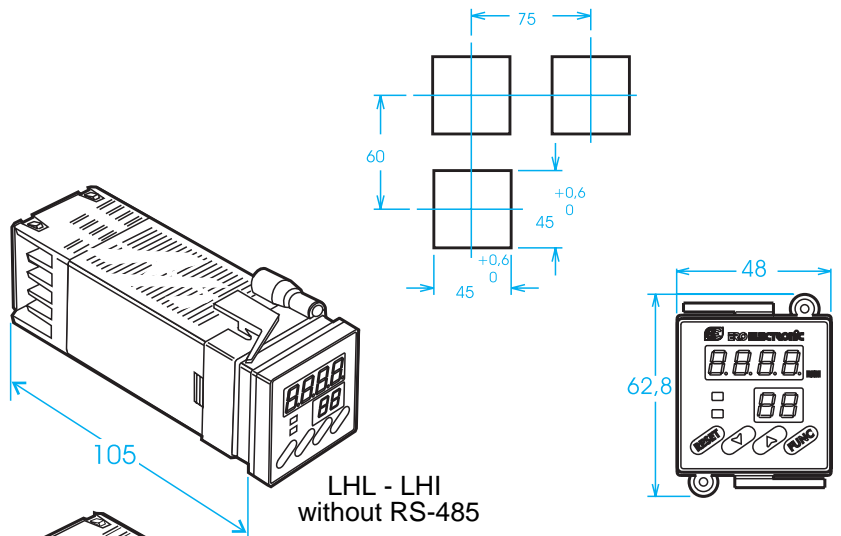

## Rear of board version

