



laser- captor

Type 611- / 611-.41

Technical Documentation

weber

Sensors Inc

Member of the captor Group

2230 Towne Lake Pkwy., Bldg. 900, Suite 200 • Woodstock, GA 30189

Phone: +1(770)592-6630 • Fax: -6640 • E-mail: info@captor.com • www.captor.com

laser - captor



Type 611- / 611-.41

Installation Instructions

Please read carefully: No liability can be accepted for damage caused by improper use of the captor.

1. Mounting

a. Install the transmitter and receiver so that they face each other.

For best mounting and alignment use the special swivel stands which are part of the system.

When choosing the mounting position and installing the units, ensure that the units are

- * on a fixed and stable surface
- * in a vibration-free place
- * protected against unintentional / accidental shifting of the alignment
- * protected against dirt accumulation
- * protected against ambient and radiation temperatures above 55°C.

b. Ensure that the protective caps are mounted as far as the mechanical stop and secured tightly with the three screws (spanner SW7).

The optimum power transfer function of the laser-captor can only be reached with clean lenses. The protective caps provided help maintain this but an extension tube with air purge is also available if necessary.

For receivers with a control output option, a control potentiometer (**C**) is mounted on the receiver. A warning signal (≤ 2 V) is switched when dirt accumulates on the lenses; the control potentiometer adjusts the sensitivity to the dirt:

Counterclockwise (scale 1):

Control output low signal when lens
has max. fouling (max. sensitivity
= min. attenuation)

Clockwise (scale 10):

Control output low signal when lens
has min. fouling (min. sensitivity
= max. attenuation)

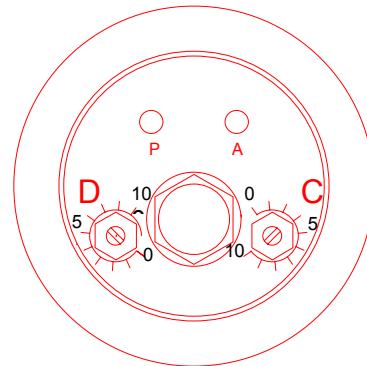

2. Electrical connection:

Connect the cable of the transmitter and receiver according to the connection diagram.

Supply:	brown	(1)	: Supply voltage +24 V DC (tolerance 19,2.....28,8 V DC)
	blue	(2)	: Supply voltage ground
	yellow / green		: Protective ground (internally connected to voltage ground)
Receiver outputs	black / yellow	(3)	: Alarm output } n.c. relay contact
	black	(5)	: Alarm output
	yellow	(4)	: control output (pnp-transistor, load to be connected to voltage ground)

weber

Sensors Inc

2230 Towne Lake Pkwy., Bldg. 900, Suite 200 • Woodstock, GA 30189

Member of the captor Group

Phone: +1(770)592-6630 • Fax: -6640 • E-mail: info@captor.com • www.captor.com

laser - captor



Type 611- / 611-.41

Installation Instructions

Please read carefully: No liability can be accepted for damage caused by improper use of the captor.

2. (cont.) Electrical connection:

The alarm output relay is activated when receiving the laser beam. In this state the relay contact is open.

Max contact load. 2 A, 125 VAC/ 30 VDC

The response time delay can be adjusted by the delay potentiometer (**D**):

- counterclockwise (scale 0) < 20 ms
- clockwise (scale 10) > 800 ms

3. Power supply

Switch on the power supply.

The green LED (P) of the transmitter should be on - indicating that the laser beam is present.

The green LED (P) of the receiver should be on - indicating that the unit is operating. The red LED (A) will be lit if the unit cannot "see" the laser beam.

4. Alignment

Pivot the transmitter and the receiver alternately in the vertical and horizontal axle so that there is an initial laser beam contact and the red LED (A) of the alarm output is off.

For an optimum alignment please see the separate alignment instructions

weber

Sensors Inc

Member of the captor Group

2230 Towne Lake Pkwy., Bldg. 900, Suite 200 • Woodstock, GA 30189

Phone: +1(770)592-6630 • Fax: -6640 • E-mail: info@captor.com • www.captor.com



laser - captor

Type 611- / 611-.41

Installation Instructions

Please read carefully: No liability can be accepted for damage caused by improper use of the captor.

General alignment instructions:

The laser-captor should be accurately aligned to ensure optimum operation, i.e the center of the laser beam should point to the center of the receiver.

It is useful, for alignment purposes, to connect a bright light to the alarm relay such that the light switches off when contact is made between the transmitter and receiver.

For fine alignment, the sensitivity can be reduced by covering the lenses with card discs with central holes as follows:

Transmitter	central hole 5 mm
Receiver	central hole 10 mm

An alternative method would be to use opaque adhesive tape, instead of card discs.

1.0 Rough alignment

1.1 Align by targeting the transmitter with the receiver.

1.2 Then align by targeting the receiver with the transmitter, if necessary pivot the receiver slowly along the x and / or y axis until the first laser beam contact occurs.

Adjust the units until contact is made, when LED "A" on the receiver goes off, and the light (if connected) goes off.

2.0 Fine alignment of transmitter

2.1 Pivot the transmitter slowly around the x-axis(s. drawg. no. 413831-2.KAT, REV:AB) Place two marks on the swivel stand or on the housing at the two points where contact is lost and the alarm LED (and the light) is illuminated. Adjust the transmitter equally between the two marks (ideal alignment position).

Secure the unit (temporarily) on the swivel stand with the screws provided (3x M5).

2.2 Repeat step 2.1 for the y-axis.

2.3 Reduce the sensitivity with card discs as described in the general alignment instructions.

2.4 Re-check the alignment of the x axis and make corrections if necessary.

2.5 Finally secure the unit in the x-axis (3x M5).

2.6 Re-check the alignment of the y axis and make corrections if necessary.

2.7 Finally secure the unit in the y axis (M8).

weber

Sensors Inc

2230 Towne Lake Pkwy., Bldg. 900, Suite 200 • Woodstock, GA 30189

Member of the captor Group

Phone: +1(770)592-6630 • Fax: -6640 • E-mail: info@captor.com • www.captor.com



laser - captor

Type 611- / 611-.41

Installation Instructions

Please read carefully: No liability can be accepted for damage caused by improper use of the captor.

3.0 Fine alignment of receiver

3.1 Proceed as for the transmitter above (step 2.1 to 2.7).

4.0 Final handling

Remove any card discs or adhesive tapes used to reduce sensitivity and clean the lenses with a soft cloth.

Mount the protective caps or extension tubes, ensuring that they are mounted as far as the end stops and securely fastened with the three screws (spanner SW7).

5.0 Test of the alarm function

Test the accuracy of the alarm and control output function by interrupting the laser beam several times with a piece of paper or cardboard.

6.0 Threshold adjustment of the control output

Please see under "Mounting" 1b.

weber

Sensors Inc

Member of the captor Group

2230 Towne Lake Pkwy., Bldg. 900, Suite 200 • Woodstock, GA 30189

Phone: +1(770)592-6630 • Fax: -6640 • E-mail: info@captor.com • www.captor.com