

NEW  
IMPROVED  
ACCURACY

*Penny+Giles*  
YOUR PARTNERS  
*In Control*

# LVDT Displacement Transducers



**Creative solutions  
for position measurement and control**

# LVDT Technology

## Penny+Giles LVDT's

The Penny+Giles range of rugged, high integrity LVDT displacement transducers are designed for operation in harsh automotive and industrial environments. The design elements employed have evolved from the technology and experience gained over 40 successful years in the aerospace/military sensor market, where performance and reliability under extreme operating conditions are paramount.

For an explanation of how LVDT's operate, see page 10.

### High accuracy system performance

These LVDT displacement transducers have been designed primarily for use in the "difference over sum" (or ratiometric) configuration to provide high system accuracy performance where the output is virtually unaffected by temperature and supply changes. As the sum of the secondary output coil voltage ( $V_a + V_b$ ) is nominally constant throughout the stroke range, Penny+Giles sensors can be employed for system error detection in high integrity systems. Alternatively, the sensors can be used in the differential output configuration, with lower system accuracy.

For optimum performance of these LVDT's we recommend the use of the purpose designed Signal Conditioning Module which is detailed on page 8. **The Penny+Giles LVDT and SCM module are designed to make using an LVDT as simple as using a linear potentiometer.**

Features	Benefits
<ul style="list-style-type: none"> <li>• No contact between the sensing elements                             <ul style="list-style-type: none"> <li>• Infinite resolution</li> <li>• Absolute measurement</li> <li>• Excellent repeatability</li> </ul> </li> <li>• Small transducer body length to stroke ratio</li> <li>• Welded and vacuum brazed stainless steel construction                             <ul style="list-style-type: none"> <li>• Sealed to IP66</li> <li>• Temperature Range -35° to +125°C</li> </ul> </li> <li>• High integrity coil, screen and connection assemblies                             <ul style="list-style-type: none"> <li>• Screened and sheathed interface cable</li> <li>• Temperature error less than 35ppm/°C</li> </ul> </li> </ul>	<ul style="list-style-type: none"> <li>• Virtually infinite life and fast dynamic response</li> <li>• All displacement will be sensed</li> <li>• No loss of position on power down</li> <li>• Can perform very precise go/no-go applications</li> <li>• Minimal operational footprint and weight</li> <li>• Maximum reliability in hostile environments</li> <li>• High performance in electrically noisy environments</li> <li>• Maximises system accuracy</li> </ul>

## Selection Guide

Penny+Giles offers the widest choice of options to suit your application.

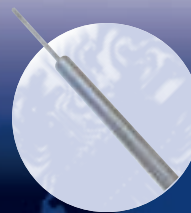

**AF111** page 4

The AF111 range is ideally suited to a number of industrial applications such as vehicle research, test rigs and OEM machinery.



**AF145** page 6

The AF145 range is suited to harsh automotive and industrial environments, with a compact body length and an outer sliding sleeve design which enhances the transducer rigidity over its operating range.



#### EMC Directive 89/336/EEC

The LVDTs and Signal Conditioning Module SCM100 detailed in this document have been tested together as a system, to the requirements of EN50081-1 (Emissions) and EN50082-2 (Immunity).



## Separate signal conditioning

By keeping the signal conditioning electronics away from the transducer the full potential of the LVDT is realised and not compromised by the presence of sensitive electronics.

The result is a more reliable transducer solution, easily installed, adjusted and with a greater choice of signal inputs and outputs.

The electronics have been tested to operate 25 metres from the LVDT, with the output driving 240 metres of cable.

## Total reliability

The LVDT transducer system provides a highly reliable solution for position sensing, particularly in hostile environments. The contactless operating principle allows a fit and forget installation so that zero maintenance programmes can be incorporated within plant service schedules.

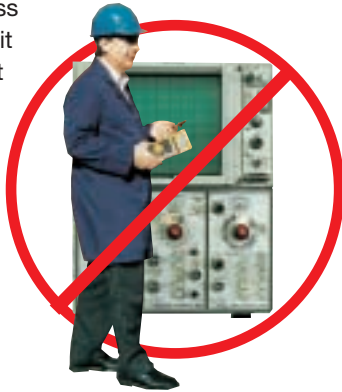

**NO MAINTENANCE**

## Choice of mounting

Penny+Giles LVDT's are offered with two standard mounting configurations. Model AF111 has a conventional threaded core attachment, with a body suitable for clamp mounting.

Model AF145 utilises the popular self aligning bearing mounting style which can accommodate minor misalignment at the mounting attachments. Model AF145 also includes an outer sleeve, protecting the movable core whilst enhancing the rigidity of the transducer during operation.



## In stock availability

These LVDT displacement transducers are designed to provide the user with the most popular choice of mounting styles for a wide range of industrial applications. Stroke ranges from 5mm to 150mm are available from stock, so call your nearest sales office for the latest information.

## Custom design

For larger scale users, we offer a custom design service which can customise either the mounting arrangement or shaft assembly to suit a specific system requirement.



### Conditioning Module SCM100 page 8

Input: 18-30 or  $\pm 15$ Vd.c.  
Output: 0-5, 0-10 or  $\pm 10$ Vd.c.  
or 4-20mA

The SCM100 conditioning module is designed specifically to operate the Penny+Giles range of LVDTs. The module is contained in a DIN rail enclosure and has span and null adjustment features to aid the installation of the LVDT.



## Single channel LVDT panel indicators - DML300 series

Designed specifically for use with LVDT transducers. Please ask for the separate brochure which details the features of the range.

# LVDT AF111

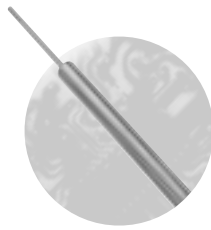

The AF111 range of high accuracy LVDT displacement transducers have been designed primarily for use in the ratiometric configuration and have a compact size, with stroke lengths from 5mm to 150mm. Suitable for clamp mounting, the AF111 range have a threaded, unguided core assembly to simplify installation. Suited to numerous industrial applications, such as vehicle research, test rigs and OEM machinery.

## PERFORMANCE

Electrical stroke E	mm	5	15	25	50	75	100	125	150
	±	2.5	7.5	12.5	25.0	37.5	50.0	62.5	75.0
Input voltage and frequency		1 to 10VRMS at 400Hz to 12.5kHz (sinewave)							
Insulation resistance		Greater than 100MΩ at 500Vd.c.							
Operational temperature	°C	-35 to +125							
Storage temperature	°C	-55 to +135							
Vibration		RTCA/DO - 160C, Section 8, Fig 8 - 1 Curve C (Random), 10 - 2000Hz, 4.12g rms RTCA/DO - 160C, Section 8, Fig 8 - 3 Curve L (Sine), 10 - 2000Hz, 3g rms							
Environmental protection		IP66							

## RECOMMENDED MODE

**a.c. operation - High accuracy ratiometric mode - specification at 3VRMS, 2.5kHz @ 20°C unless stated otherwise**

Electrical output R proportional to position		$R = \frac{V_a - V_b}{V_a + V_b}$							
Electrical output R at extremes from null	±1% total stroke	0.3	0.3	0.4	0.4	0.6	0.6	0.6	0.6
Non-linearity	±% total stroke	0.2	0.2	0.2	0.2	0.125	0.125	0.125	0.125
Secondary coil output voltage		3.3VRMS maximum							
Input impedance		Greater than 300Ω							
Load resistance (per coil)		Greater than 50kΩ (non reactive)							
Temperature error (maximum)	% total stroke/°C	0.0012	0.0012	0.0012	0.0018	0.0018	0.0035	0.0030	0.0030

**a.c. operation - Lower accuracy differential mode - typical specification at 3VRMS, 2.5kHz @ 20°C unless stated otherwise**

Non-linearity		±0.30% total stroke							
Sensitivity (in phase)	mV/V/mm	80.0	44.0	39.0	20.0	18.0	13.0	10.5	9.0
Phase shift (fully extended)		20°	20°	15°	15°	5°	5°	5°	5°
Input impedance (minimum)		Greater than 300Ω							
Null voltage	% total stroke output	1.0	1.0	1.0	0.5	0.5	0.5	0.5	0.5

## OUTPUT SCHEMATICS

### Ratiometric configuration

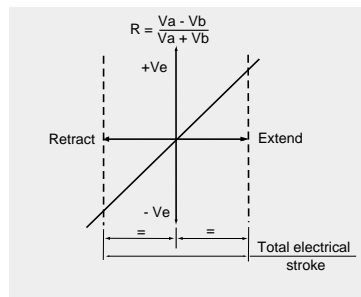

### Differential configuration

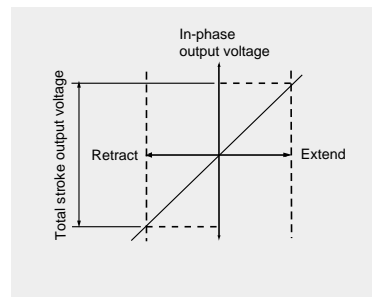

## DIMENSIONS

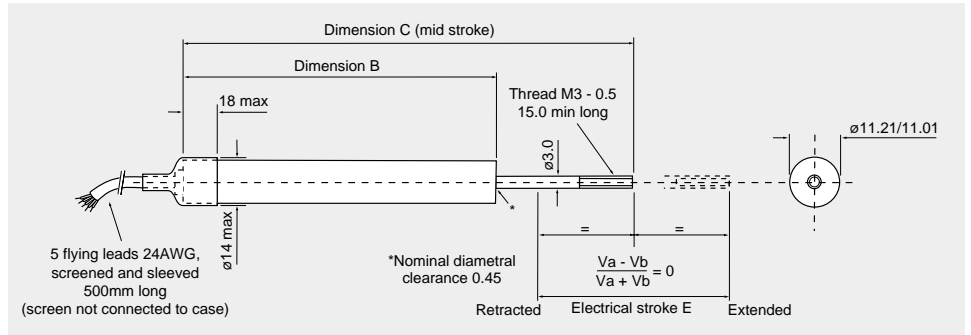

Electrical stroke E	mm	5	15	25	50	75	100	125	150
Mechanical stroke M (non captive shaft)	mm	9	19	29	54	79	104	129	154
Dimension B	mm	55	65	80	105	150	175	215	240
Dimension C	mm	75	90	110	147.5	205	242.5	295	332.5
Weight (maximum)	g	45	50	55	67	90	100	120	140

## ELECTRICAL CONNECTIONS

5 flying leads 24AWG, screened and sleeved and sleeved 500mm long

### Ratiometric connection configuration

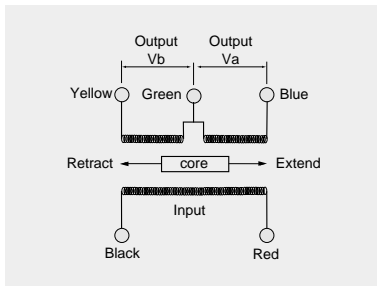

### Differential connection configuration

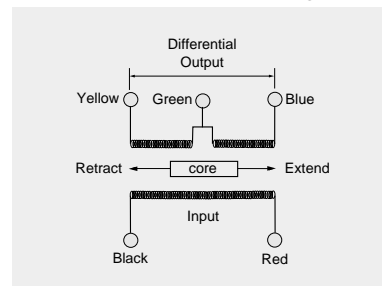

### Phasing notes:

#### (i) High accuracy Ratiometric mode

When the LVDT is connected to the SCM100 module, there is no requirement to determine the phasing of the output to the input. The high performance circuit of the SCM100 determines all relevant parameters and supplies d.c. outputs as shown on page 8.

#### (ii) Lower accuracy Differential mode

In this mode, the LVDT is used without the SCM100 module and could be connected to a third party signal conditioning module. With the black and blue leads common, the output on the yellow lead will be in-phase with the red lead (input) as the shaft retracts from the null position.

## AVAILABILITY

Normally available from stock

## ORDERING CODES

AF111/.....

Electrical stroke (total) mm

e.g. AF111/125 has 125mm total stroke

# LVDT AF145



The AF145 range of high accuracy LVDT displacement transducers have been designed primarily for use in the ratiometric configuration, and have a compact size, with stroke lengths from 5mm to 150mm. The AF145 has self-aligning rod end bearing mounting, with an outer sliding sleeve which protects the movable core whilst enhancing the rigidity of the transducer during operation. Suited to harsh automotive and industrial environments.

## PERFORMANCE

Electrical stroke E	mm	5	15	25	50	75	100	125	150
	±	2.5	7.5	12.5	25.0	37.5	50.0	62.5	75.0
Input voltage and frequency		1 to 10VRMS at 400Hz to 12.5kHz (sinewave)							
Insulation resistance		Greater than 100MΩ at 500Vdc							
Operational temperature	°C	-35 to +125							
Storage temperature	°C	-55 to +135							
Vibration		RTCA/DO - 160C, Section 8, Fig 8 - 1 Curve C (Random), 10 - 2000Hz, 4.12g rms RTCA/DO - 160C, Section 8, Fig 8 - 3 Curve L (Sine), 10 - 2000Hz, 3g rms							
Environmental protection		IP66							

## RECOMMENDED MODE

**a.c. operation - High accuracy ratiometric mode - specification at 3VRMS, 2.5kHz @ 20°C unless stated otherwise**

Electrical output R proportional to position		$R = \frac{V_a - V_b}{V_a + V_b}$							
Electrical output R at extremes from null	±1% total stroke	0.3	0.3	0.4	0.4	0.6	0.6	0.6	0.6
Non-linearity	±% total stroke	0.2	0.2	0.2	0.2	0.125	0.125	0.125	0.125
Secondary coil output voltage		3.3VRMS maximum							
Input impedance		Greater than 300Ω							
Load resistance (per coil)		Greater than 50kΩ non reactive							
Temperature error (maximum)	% total stroke/°C	0.0012	0.0012	0.0012	0.0020	0.0020	0.0030	0.0030	0.0030

**a.c. operation - Lower accuracy differential mode - typical specification at 3VRMS, 2.5kHz @ 20°C unless stated otherwise**

Non-linearity		±0.30% total stroke							
Sensitivity (in phase)	mV/V/mm	80.0	44.0	39.0	20.0	18.0	13.0	10.5	9.0
Phase shift (fully extended)		20°	20°	15°	15°	5°	5°	5°	5°
Input impedance (minimum)	Ω	Greater than 300Ω							
Null voltage	% total stroke output	1.0	1.0	1.0	0.5	0.5	0.5	0.5	0.5

## OUTPUT SCHEMATIC

### Ratiometric configuration

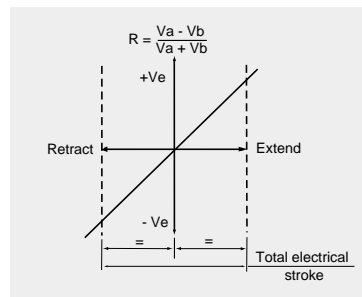

### Differential configuration

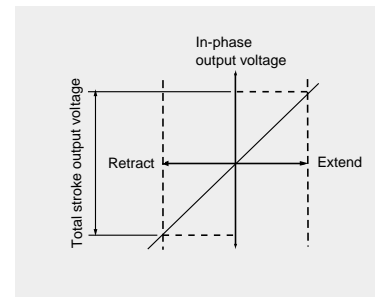

## DIMENSIONS

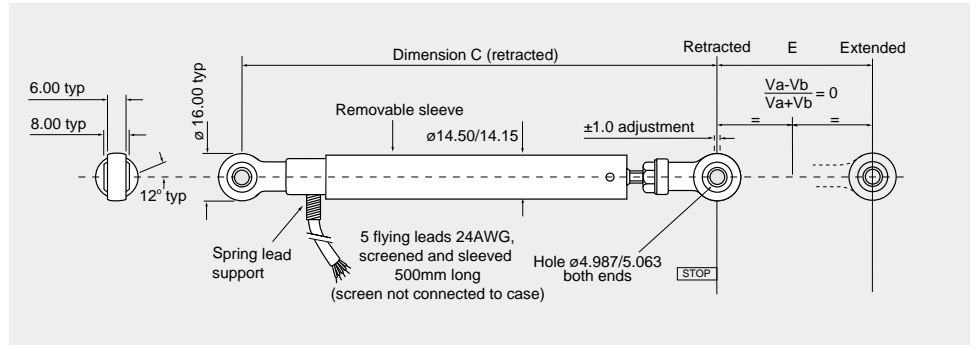

Electrical stroke E	mm	5	15	25	50	75	100	125	150
Mechanical stroke M (non captive shaft)	mm	9	19	29	54	79	104	129	154
Dimension C retracted	mm	100	110	125	150	195	220	260	285
Weight (maximum)	g	65	80	90	115	155	175	200	220

## ELECTRICAL CONNECTIONS

5 flying leads 24AWG, screened and sleeved 500mm long.

### Ratiometric connection configuration

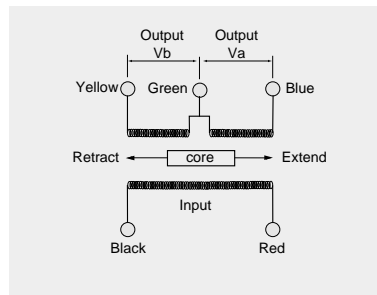

### Differential connection configuration

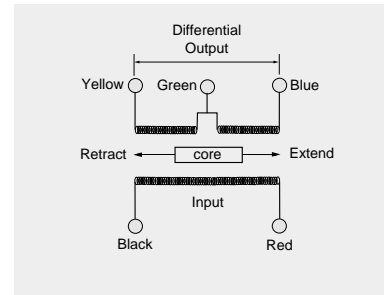

### Phasing notes:

#### i) High accuracy Ratiometric mode

When the LVDT is connected to the SCM100 module, there is no requirement to determine the phasing of the output to the input. The high performance circuit of the SCM100 determines all relevant parameters and supplies d.c. outputs as shown on page 8.

#### (ii) Lower accuracy Differential mode

In this mode, the LVDT is used without the SCM100 module and could be connected to a third party signal conditioning module. With the black and blue leads common, the output on the yellow lead will be in-phase with the red lead (input) as the shaft retracts from the null position.

## AVAILABILITY

Normally available from stock

## ORDERING CODE

AF145/.....

Electrical stroke (total) mm \_\_\_\_\_

e.g. **AF145/100** has 100mm total stroke

# LVDT

## d.c./d.c. Driver SCM100



The LVDT Signal Conditioning Module SCM 100 has been specifically designed to operate with the AF111 and AF145 range of LVDT's, and to make using an LVDT as simple as using a linear potentiometer. This module incorporates a high performance circuit which drives the LVDT in a ratiometric configuration, thereby maximising system accuracy by eliminating effects caused by temperature and supply current variations.

### PERFORMANCE

Supply voltage	18 - 30Vd.c. (regulated) or $\pm 15$ Vd.c. (regulated)
Supply current	100mA maximum
LVDT excitation voltage	3VRMS (nominal)
LVDT excitation frequency	2.5kHz (nominal)
Output voltage* (SCM100/V)	See output options chart below for full details
Output current (SCM100/I)	See output options chart below for full details
Output ripple	<5mVRMS
Output load	1k $\Omega$ minimum (resistive) - voltage and current output
Non-linearity	$\pm 0.05\%$ max (over 1% to 99% of stroke when used with AF111 or AF145 LVDT's)
Line regulation	<0.01% output span/Volt
Load regulation	<0.05% output span (minimum to maximum load)
Output adjustment range	
-null adjustment	$\pm 25\%$
-gain adjustment	$\pm 10\%$
Operational temperature	0 to +70°C
Storage temperature	-20 to +85°C
Temp. coeff. of output	<0.01% of span volts/°C
Transducer types	5 wire ratiometric LVDT only
Mechanical housing	Entrelec 11000 series (to suit DIN EN50022/EN50035 rails)
Weight maximum	100g

\* When powered with a single rail supply, the output may not quite reach 0 Vd.c. For this reason, linearity is specified for 1% to 99% of LVDT stroke.

### OUTPUT CHARACTERISTICS

18 - 30Vd.c. supply

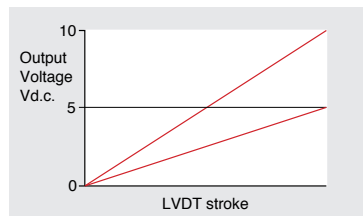

18 - 30Vd.c. or  $\pm 15$ Vd.c. supply

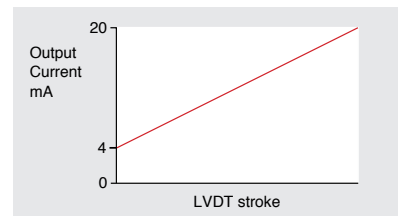

$\pm 15$ Vd.c. supply

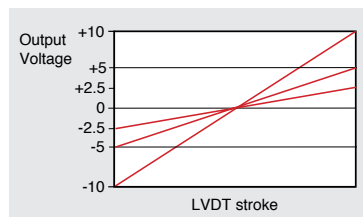

**Note:** This module is user configurable for input and output options. See set-up guide supplied with module for full instructions.

### OUTPUT OPTIONS

Output option	Power supply option	
	18 - 30Vd.c.	$\pm 15$ Vd.c.
$\pm 2.5$ Vd.c.	N/A	✓
$\pm 5$ Vd.c.	N/A	✓
$\pm 10$ Vd.c.	N/A	✓
0 - 5Vd.c.	✓	✓
0 - 10Vd.c.	✓	✓
4 - 20mA (SCM100/I only)	✓	✓
Slope reversal	✓	✓

# LVDT

---

## d.c./d.c. Driver SCM100

### DIMENSIONS

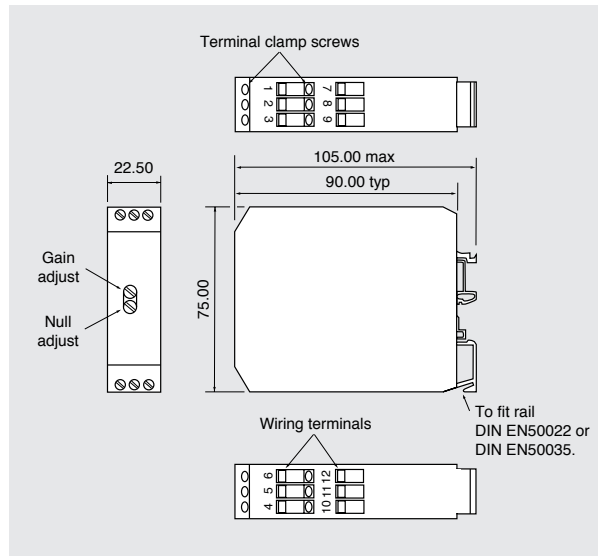

### ELECTRICAL CONNECTIONS

Screw terminals

Note:

Refer to the SCM100 set-up guide for details on how to connect to a  $\pm 15\text{Vd.c.}$  (split rail) power supply.

**Misconnection of the supply may cause permanent damage.**

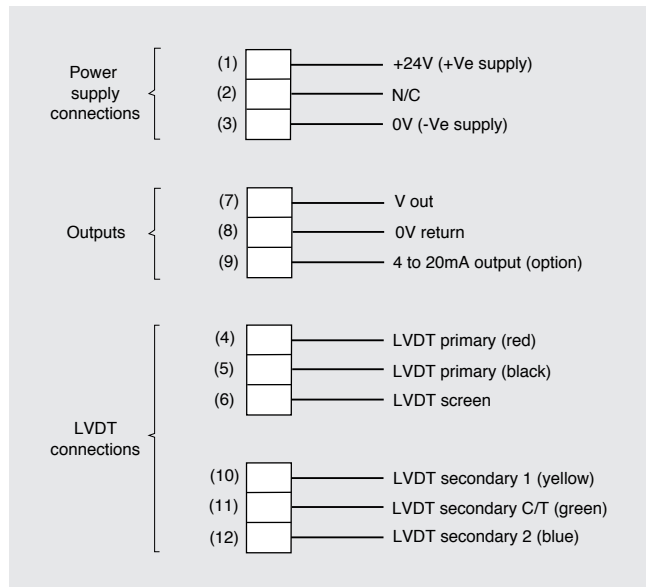

### AVAILABILITY

Normally available from stock

### ORDERING CODES



# LVDT Displacement Transducers -

## Operation and Use

### What is an LVDT?

LVDT is the acronym for Linear Variable Differential Transformer. The LVDT is a non-contacting linear displacement transducer which works on a principle of mutual inductance, producing an electrical signal which is proportional to a separate moving core (or armature).

The fundamental advantages of LVDT transducers are their high degree of robustness, infinite resolution and ability to operate at high temperatures and in extreme environments.

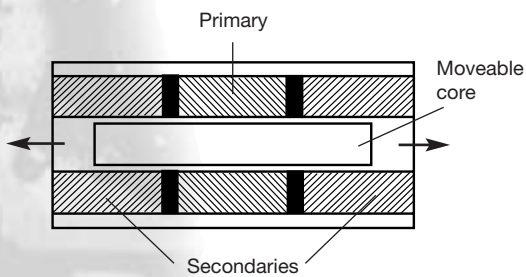

Fig A) LVDT cross sectional diagram

### LVDT principle

The LVDT consists of a primary winding, two secondary windings and a separate, moveable high permeability core (Fig A). When the primary winding is driven with an a.c. voltage a corresponding a.c. voltage is induced in the two secondary windings, in proportion to the position of the moveable core. The secondary windings are connected in series opposition to form the transformer secondary (Fig B).

When the core is centered with respect to the two secondary windings, they will have the same magnitude of induced output voltages, but the polarity (or phasing) will be opposite.

When the core is displaced from this null position, the output amplitude on one secondary coil ( $V_a$ ) increases, while the output amplitude in the other coil ( $V_b$ ) decreases (Fig C). These voltages can be used individually or combined to produce an output signal proportional to position, dependant upon the method of demodulation used. The two main methods used are described below.

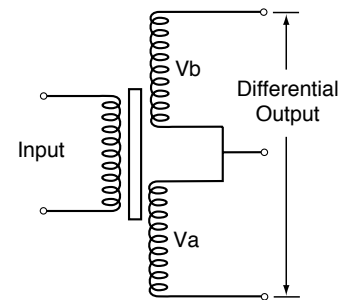

Fig B) LVDT differential output connection

### Individual output voltage schematic

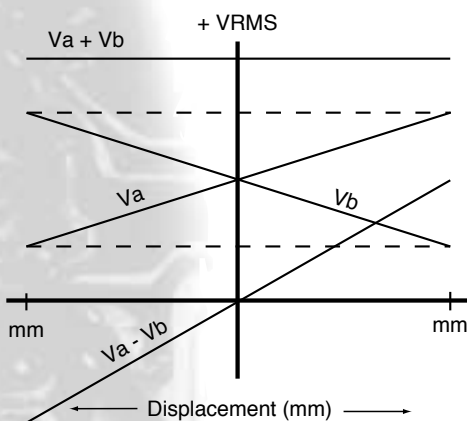

Fig C)

### Ratiometric operation

A high accuracy method of translating the LVDT output is to measure the secondary voltages independently to generate a ratio of the difference divided by the sum of these values.

$$\text{Ratio} = \frac{V_a - V_b}{V_a + V_b} \quad (\text{Fig. D})$$

This configuration is commonly referred to as ratiometric operation and will provide much higher system accuracy performance than operation in the differential mode.

Ratiometric operation provides:

- Improved immunity to LVDT supply voltage and frequency variations

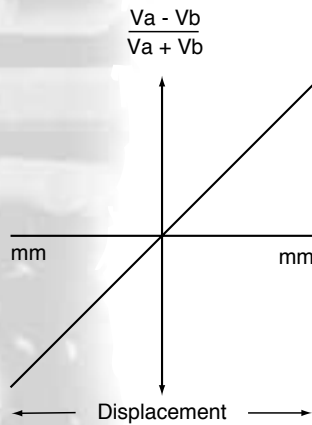

Fig D)

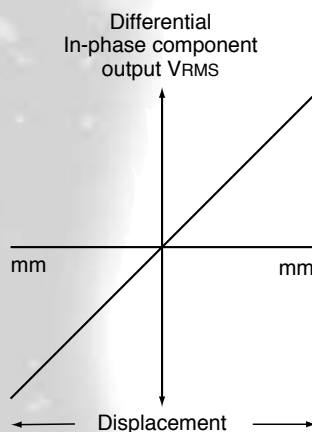

Fig E)

- Improved immunity to errors due to temperature effects on LVDT sensitivity
- Improved frequency and phase response
- Improved immunity to common-mode noise on LVDT lines
- Improved transducer interchangeability

Additionally, the sum of the secondary output voltages ( $V_a + V_b$ ) is nominally constant throughout the LVDT stroke range, so it can be used for system error detection in high integrity systems.

To operate in the ratiometric mode requires a five or six wire, centre-tapped LVDT specifically designed for the purpose, as with Penny+Giles AF145 and AF111 LVDT's.

Penny+Giles recommend the use of the SCM100 LVDT driver or DML300 LVDT Driver/Panel Indicator, which are specifically designed to operate in this mode.

### Differential operation

LVDT's are normally available with either four or five wires, where the extra wire is the centre-tap in the output. When operating in the differential mode, this centre-tap connection is often not used.

The output is taken across the whole transformer secondary, (see Fig. B). In this connection configuration, when the core is displaced from the centre null position, the output will increase in-phase with the input in one direction and anti-phase with the input in the other.

To derive the position from the LVDT, a modulator is required to provide the primary a.c. voltage in conjunction with a demodulator to translate the in-phase component transformer secondary output (Fig. E) to a d.c. signal proportional to position.

When using LVDT's in this differential mode the output will be directly affected by changes in supply voltage, operating temperature and supply frequency; and is therefore of lower accuracy.

### Comparisons

LVDT's operating in the differential mode will typically provide a temperature coefficient of sensitivity of up to 500 ppm/°C.

LVDT's which have been designed to operate in the ratiometric mode use specialist winding techniques which achieve figures almost an order magnitude better - typically as low as 12ppm/°C. This is comparable with linear potentiometers (20 to 40ppm/°C).

An additional major benefit of this special ratiometric winding technique is the reduced body-to-stroke length ratio for devices over 25mm stroke. Typically values of between 30 and 40% reduction in LVDT body length can be achieved using this technique.